

Schienensystem 60 mm

Beschreibung

Das Schienensystem (eng. busbar) ermöglicht eine schnellere Montage und Verbindung elektrischer Komponenten sowie eine höhere Dichte elektrischer Komponente auf der Flächeneinheit. Auf diese Weise spart man Montagezeit und reduziert die Verteilergöße. Das Hauptmerkmal des Schienensystems ist, dass alle Elemente auf Sammelschienen montiert werden. Dieses gewährleistet Stabilität. Außerdem werden durch den Anbau der Elemente auf die Sammelschienen schon die elektrischen Anschlüsse erstellt. Für die endgültige Verdrahtung elektrischer Elemente müssen nur noch die elektrischen Anschlüsse zu Verbrauchern gelegt werden. Die einfache Handhabung des Schienensystems zeigt sich, wenn das System nachträglich erweitert werden soll, da lediglich die Kupfersammelschienen verlängert werden müssen. Das Schienensystem von ETI bietet eine große Auswahl an Elementen zur indirekten Montage auf das Schienensystem. Im Angebot stehen auch besondere Adapter zur Auswahl, mit denen auch andere Komponente angeschlossen werden, die ansonsten auf einer Montageplatte angebaut werden.

Anwendungsbereiche und Merkmale

Die Schienensysteme werden überall dort verwendet, wo man Übersichtlichkeit und kompakte Abmessungen in Verteilerschränken ohne unnötige Verdrahtung erreichen will. Schienensysteme bieten sich auch für Veränderungen oder Erweiterungen bestehender Verteilerschränke an, da das kompaktere System Platz spart und sich so weitere Komponenten installieren lassen. In der Regel werden Schienensysteme in der Industrie verwendet, wo die Schaltschränke in Funktionsblöcke geteilt werden und elektrische Komponenten für schnellen Service oder Reparaturen leicht erkennbar sein müssen.

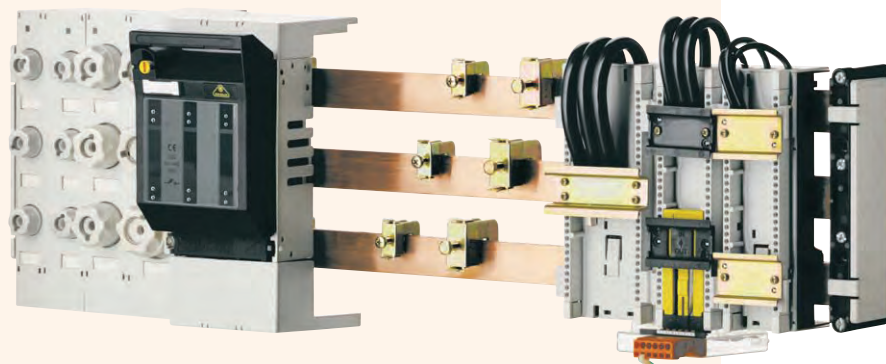

Examples:

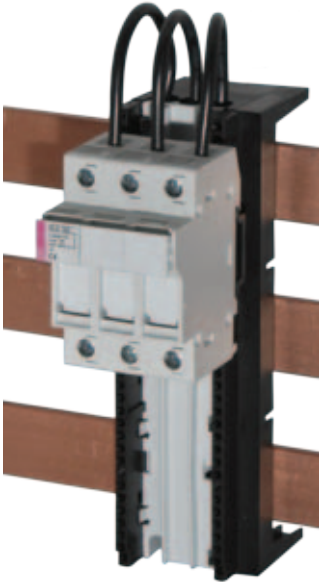

1x DA-60/32/54/1
1x VLC 10, 3-pole

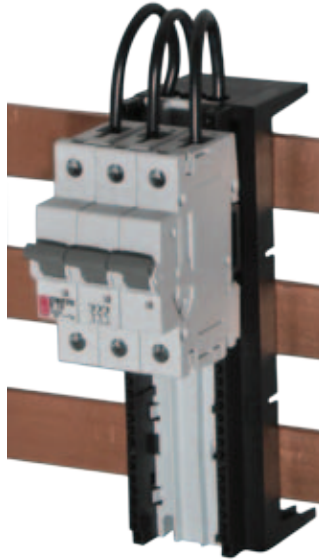

1x DA-60/32/54/1
1x ETIMAT P10, 32A

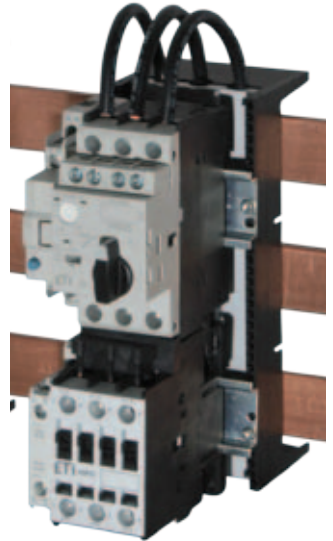

1x DA-60/32/72/2
1x MPE 25 + UVT + ECCMPE25
1x CEM 25 + BXCMLC

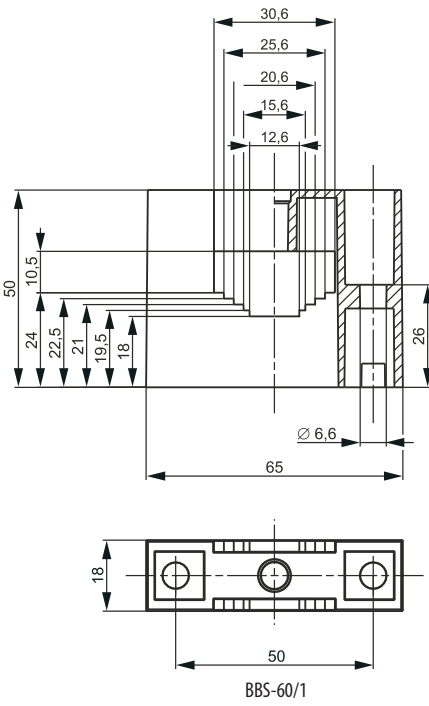

BBS-60/1

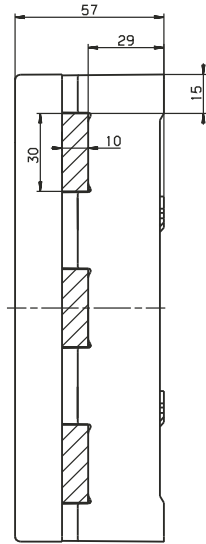

BBS-60/3

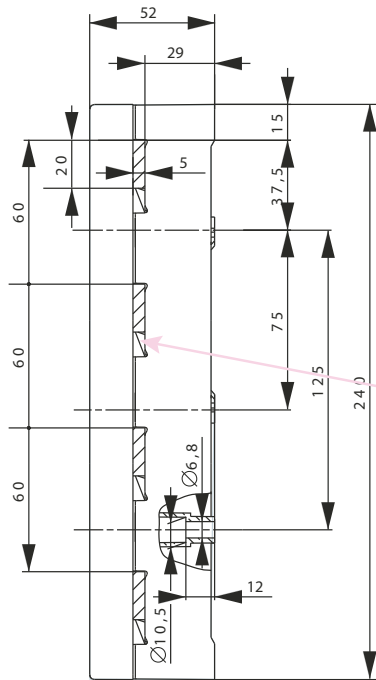
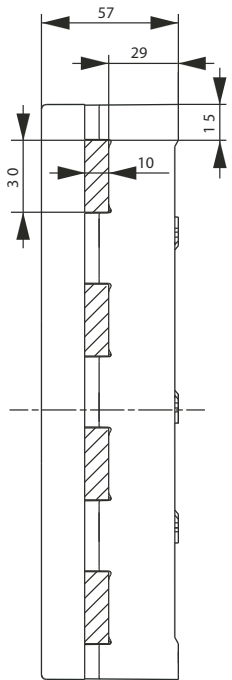
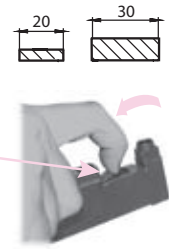
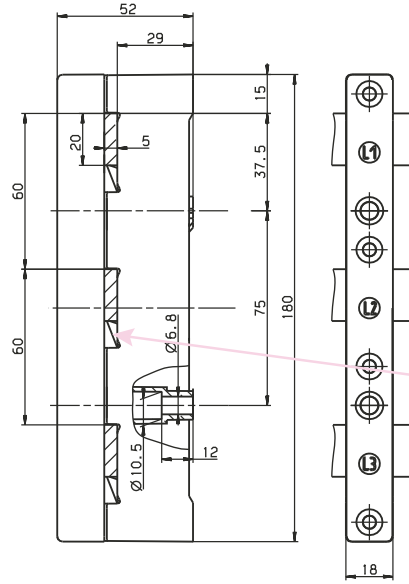

BBS-60/4

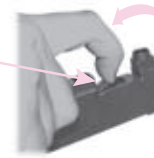
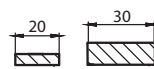
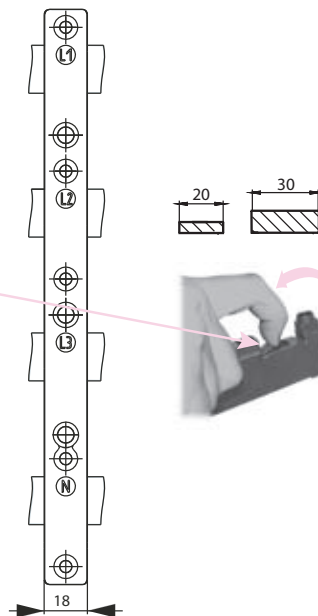

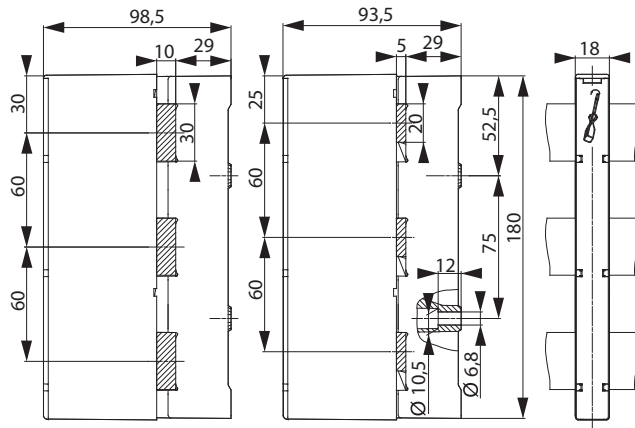

BBS-60/3-A16 (A25)

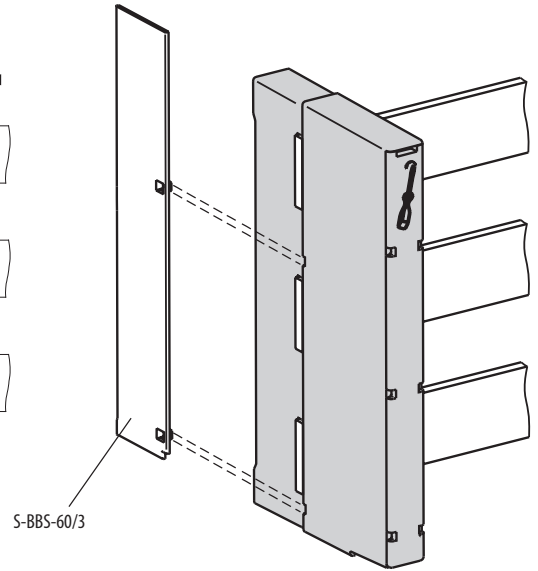

S-BBS-60/3

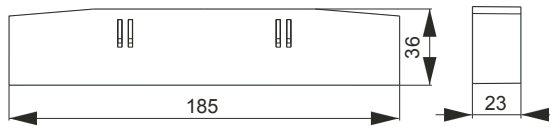

L-BBS-60/3

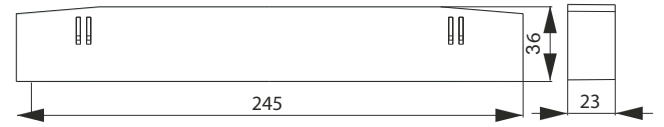

L-BBS-60/4

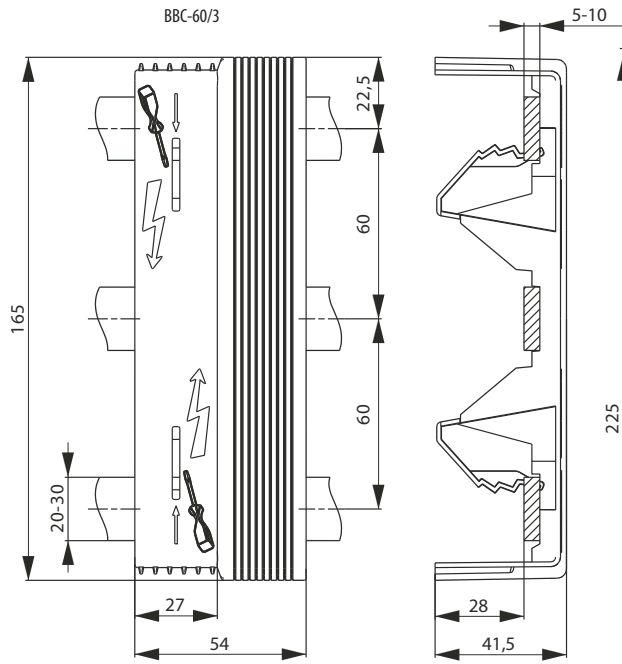

BBC-60/3

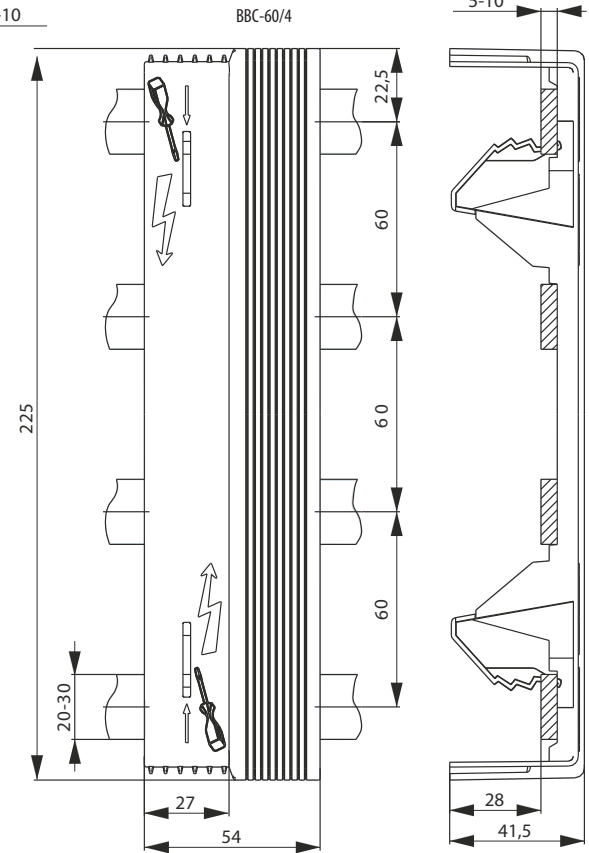

BBC-60/4



BBC-1/20, BBC-1/30

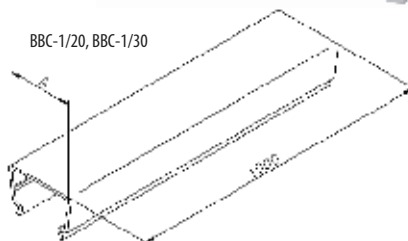

	A	Busbar Type
BBC-1/20	21	20x5 / 20x10
BBC-1/30	31	30x5 / 30x10

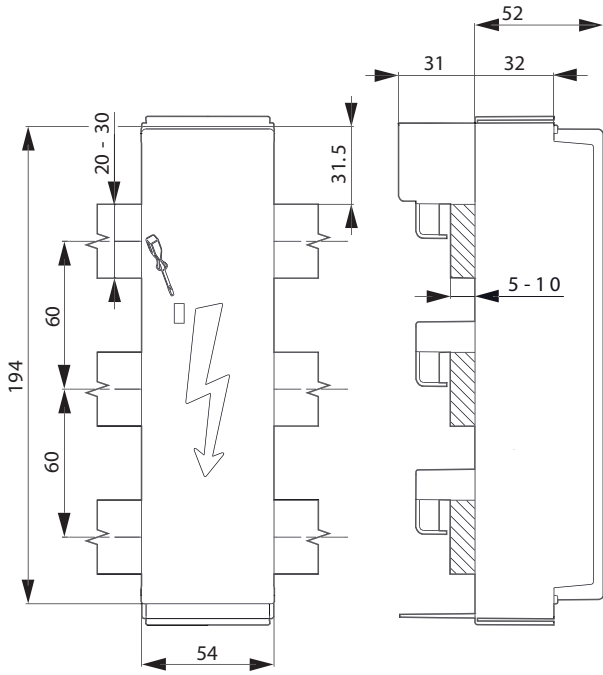

CM-60/250/3

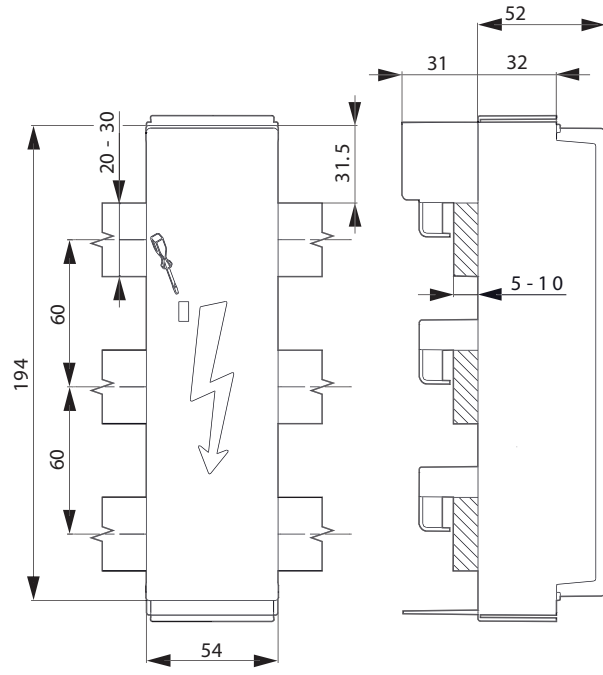

CM-60/250/4

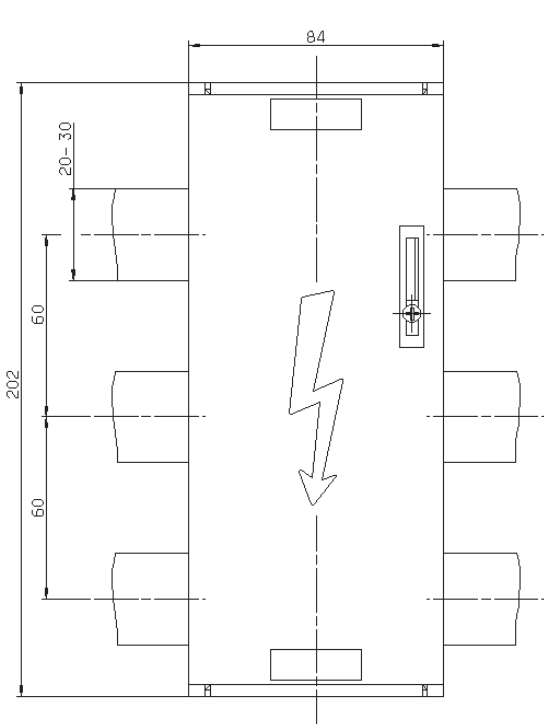

CM-60/250/3/120-5/10

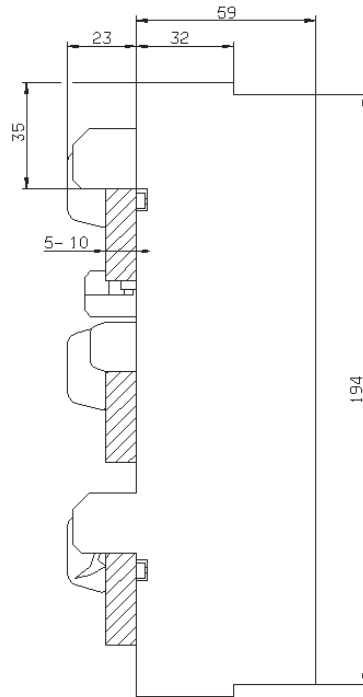

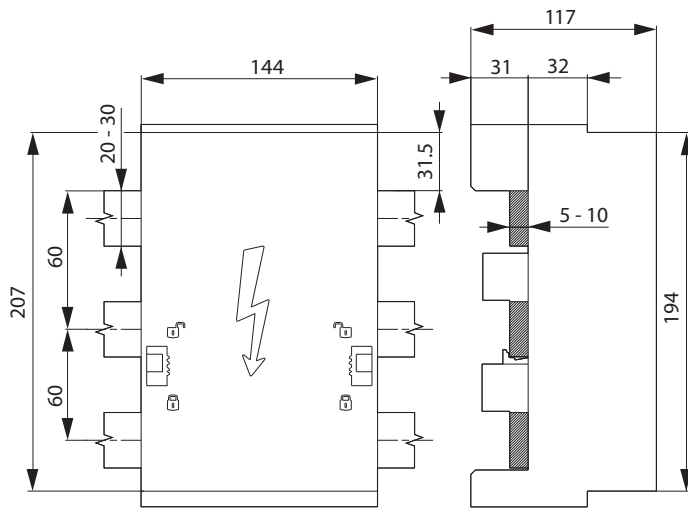

CM-60/630/3

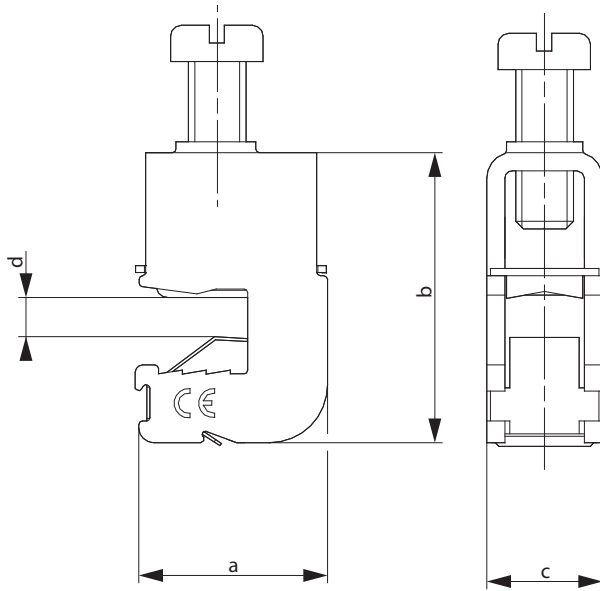

CT-...

	d (Busbar thickness)	a	b	c
CT-5/16	5	25,5	26,5	12
CT-5/35		26,5	31,5	16
CT-5/50		26,5	35	16
CT-5/70		28	39	20,5
CT-5/120		29	46	23
CT-5/185		29	49	28,5
CT-5/185	10	25,5	31,5	12
CT-10/35		26,5	36	16
CT-10/50		26,5	40	16
CT-10/70		28	39	20,5
CT-10/120		29	51	23
CT-10/185		29	53	28,5

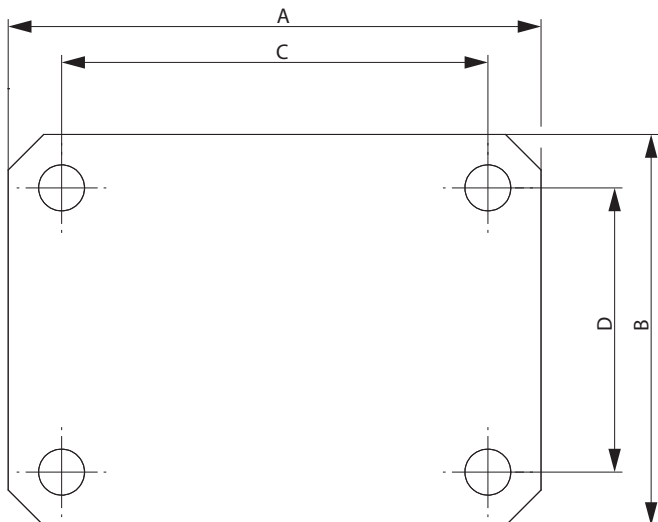

	A	B	C	D
00169031	55	55	40	40
00169150	65	55	50	40
00169151	75	55	60	40

PT-30/34x10

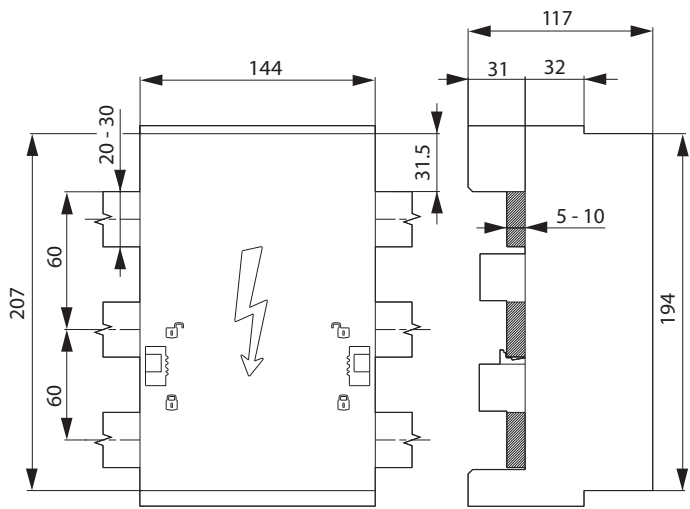

BBCH-60/144

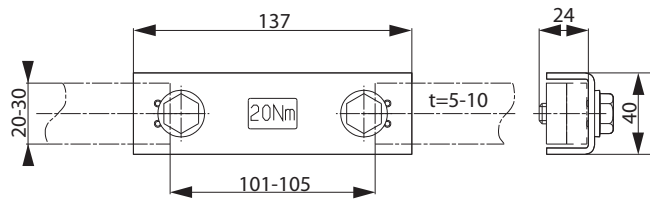

BC-20x5-30x10

Technical data (in accordance with EN 60269-1, EN 60269-2-2)

Technical Specifications				PTV-B 00 3p		PTV-B 1 3p		PTV-B 2 3p	
Electrical characteristics									
Rated operating voltage	Ue	V		690 AC		690 AC		690 AC	
Rated operating current	Ie	A		160		250		400	
Conv. thermal current with fuse links	Ith	A		160		250		400	
Conv. thermal current with solid links	Ith	A		210		325		520	
Rated frequency		Hz		40-60		40-60		40-60	
Fuse links									
Size in according to DIN 43620				00		1		2	
Max. rated current (gl/gG)	In	A		160		250		400	
Max permissible power dissipation (without fuse)	Pv	W		12		23		45	
Busbar spacing (only 3-pole)		mm		40/50/60		60		60	
Cable connection									
Flat terminal	Bolt diameter			M8		M10		M10	
	Cable lug (DIN 46235)		mm ²	1 x 10-95 (max. 25mm width)		25-150		25-240	
	Flat bar		mm	20 x 10		30 x 10		30x10	
	Tightening torque	Ma	Nm	12-15		30-35		30-35	
Clamp	Clamping range		mm ²	S00	1,5-70	S1		S2	25-240
	Tightening torque	Ma	Nm		26		95		23
Clamp	Clamping range		mm ²	P00-70	10-70	P1	70-150	P2	120-240
	Tightening torque	Ma	Nm		26		45		11
Clamp	Clamping range		mm ²	F57	1,5-70	P12	2 x 70-95	P22	1,5-70
	Tightening torque	Ma	Nm		26		40		2x120-150
Clamp	Clamping range		mm ²			K2G	35-185	K2G	35-185
	Tightening torque	Ma	Nm				40		40
Degree of protection - Frontside - Operating state						IP00			
Operating conditions									
Ambient temperature 1)	Tu	°C		-25 ... +55					
Rated operating mode				Uninterrupted duty					
Mounting position				Vertical, horizontal					
Altitude		m		< 2000					
Pollution degree				3					
Overvoltage categorie				III					

1) 35°C Normal temperature, 55°C with reduced current

NV/NH

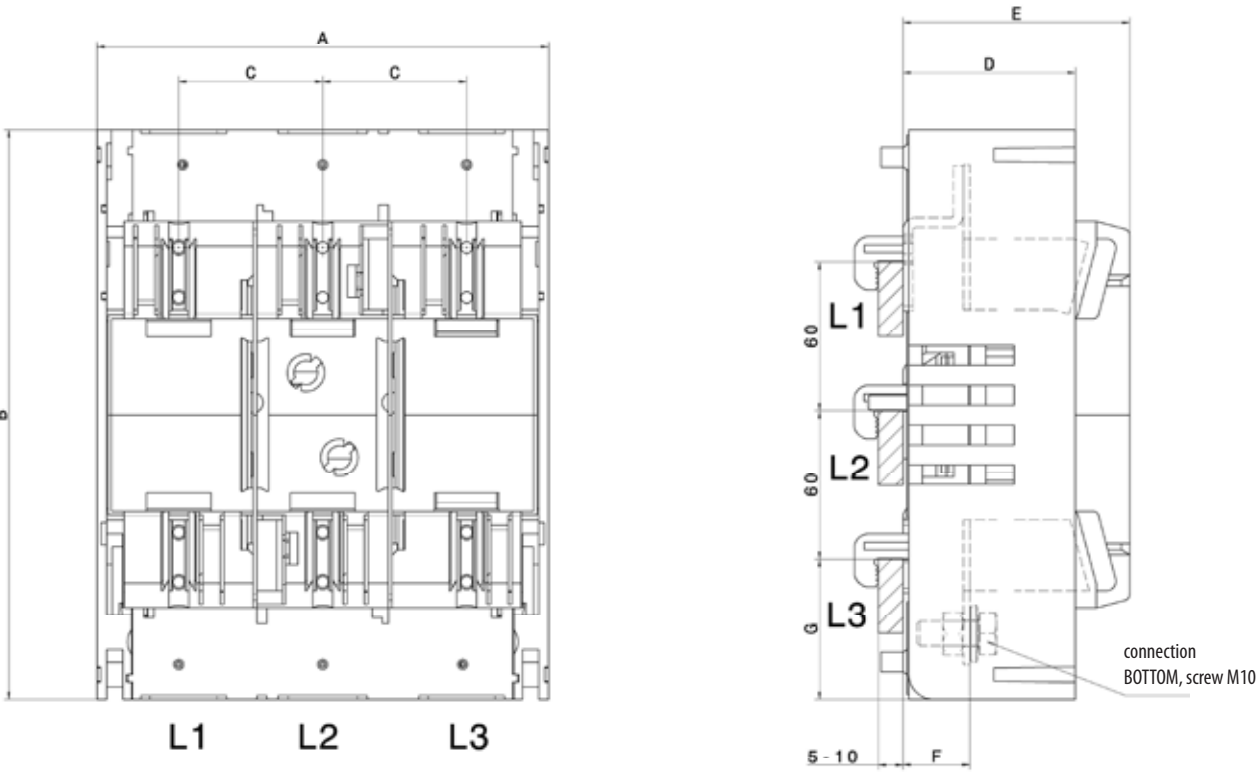
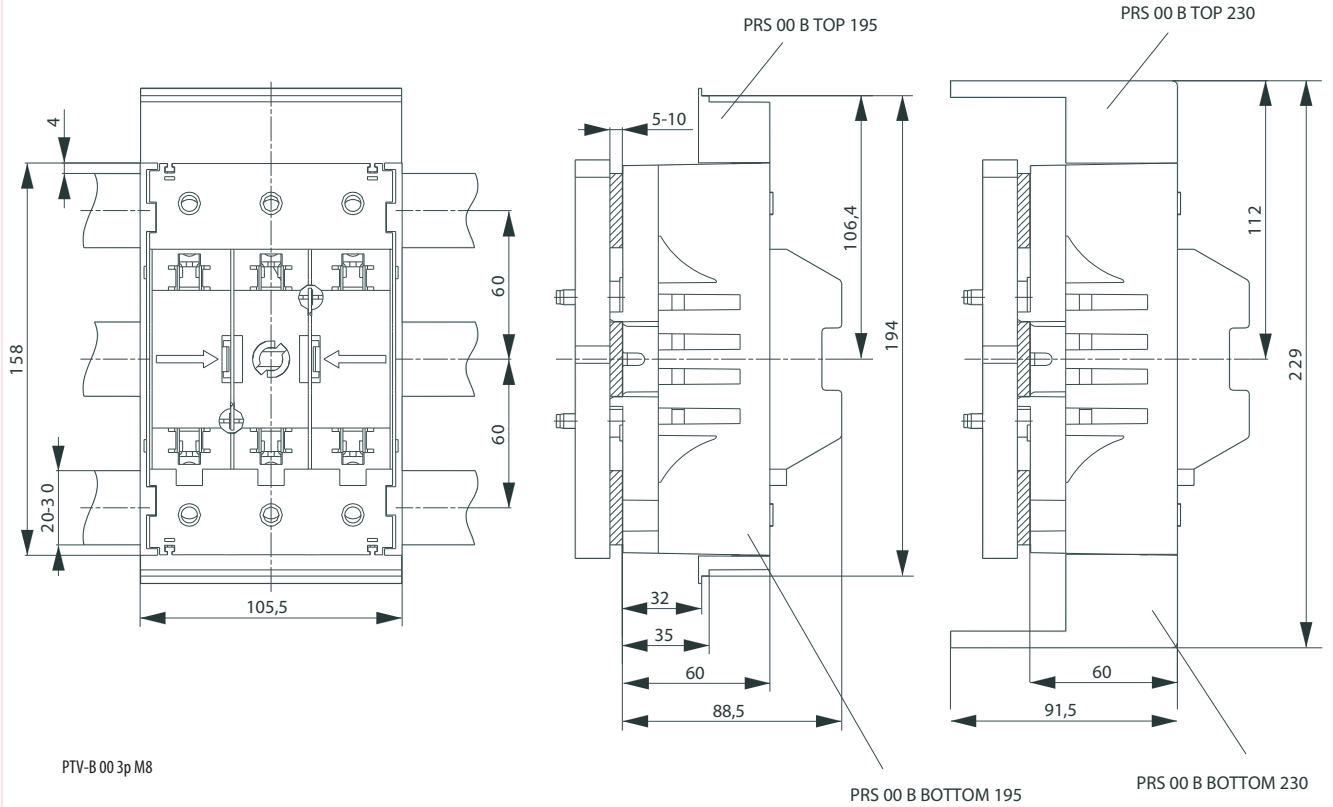

PTV-B 1 3p M10 BOTTOM, PTV-B 2 3p M10 BOTTOM

	A	B	C	D	E	F	G
HVL-B 1 3p M10 BOTTOM	184	230	58	69	92	27	57
HVL-B 2 3p M10 BOTTOM	210	256	66	83	101	27	68

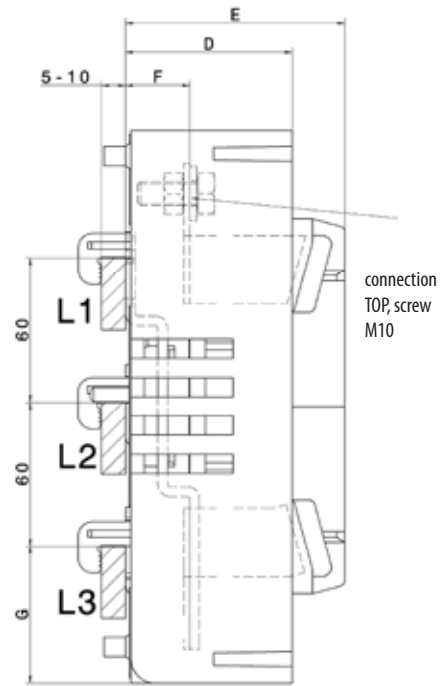
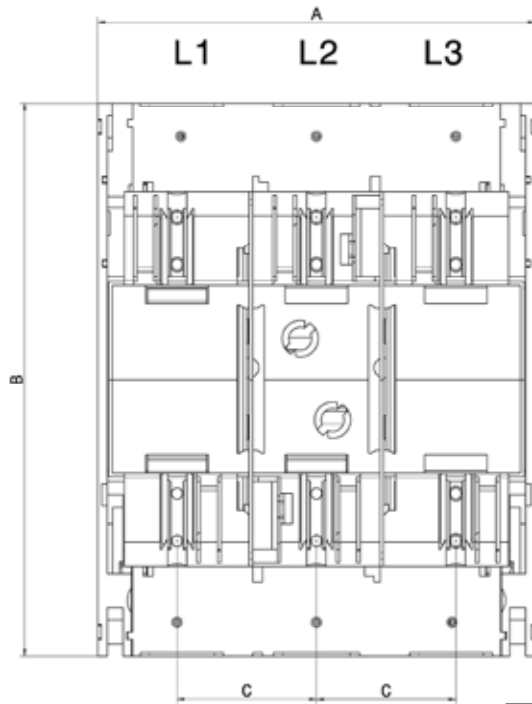

PTV-B 1 3p M10 TOP, PTV-B 2 3p M10 TOP

	A	B	C	D	E	F	G
HVL-B 1 3p M10 TOP	184	230	58	69	92	27	57
HVL-B 2 3p M10 TOP	210	256	66	83	101	27	68

Technical data (in accordance with EN 60269-1, EN 60269-2-2)

Technical Specifications			HVL-B 000 3p F57 Slim		
Electrical characteristics					
For NH fuse-links acc. to DIN VDE 0636-2	Size		0		
Rated operational voltage	Ue	V	500 AC, 220 DC		
Rated operational current 1)	Ie	A	125		
Conv. free air thermal current with fuse-links 1)	Ith	A	125		
Conv. free air thermal current with solid-links 1)	Ith	A	160		
Rated frequency	–	Hz	40-60		
Rated insulation voltage	Ui	V	500 AC		
Total power loss at Ith (without fuse-links)	Pv	W	18		
Rated impulse withstand voltage	Uimp	kV	8		
Utilization category	–	–	AC-22B (500V/125A) DC-22B (220V/100A)		
Rated conditional short-circuit current 2)	–	kA	50		
Rated short-time withstand current	Icw	kA	–		
Max. permis. power loss per fuse-link	Pa	W	8		
Cable terminal					
Clamp	Clamping cross-section	–	mm ²	F50	○: 1,5-50 Cu / □: 6 x 9 x 0,8
	Tightening torque	–	Nm		26
Degree of protection Front side	Operating condition				IP20
	Switching element open				IP10
Operating conditions					
Ambient temperature 3)	T	°C	-25 ... +55		
Rated operating mode	–	–	Uninterrupted duty		
Actuation	–	–	Dependent manual operation		
Mounting position	–	–	Vertical, horizontal		
Altitude	–	m	< 2000		
Verschmutzungsgrad/Pollution degree	–	–	3		
Überspannungskategorie/Overvoltage category	–	–	III		

1) In case of mounting of several units in low voltage switchgear-combinations, please consider rated diversity factors acc. to EN 60439-1

2) Type tested with NH-fuse-links characteristic gG

3) 35°C Normal temperature, at 55°C with reduced operating current

Technical data (in accordance with IEC/EN 60947-3 and VDE 0660, part 107)										
Technical Specifications			HVL-B 00				HVL-B 1			
Technical Characteristics										
Rated operational voltage	U_e	V	500 AC	690 AC	220 DC	440 DC	500 AC	690 AC	220 DC	440 DC
Rated operational current	I_e	A	160	100	160	100	250	200	250	200
Rated frequency	-	Hz	40-60	40-60	-	-	40-60	40-60	-	-
Rated insulation voltage	U_i	V	750 AC				750 AC			
Total power loss (without fuse)	P_v	W	6,9	2,7	6,2	2,7	12,9	8,3	8,6	5,5
Utilisation category	-	-	AC22B	AC22B	DC22B	DC21B	AC22B	AC22B	DC22B	DC21B
Fuse links										
Size - DIN 43 620	-	-	00				1			
Max. rated current (gG)	I_n	A	160	100	160	100	250	200	250	200
Max. permissible power lose per fuse link	P_v	W	12				23			
Screw	-	-	M8				M10			
Torque	M_a	Nm	12-15				30-35			
V-clip	-	mm ²	1,5-70				25-150			
Torque	M_a	Nm	2,6				9,5			
Protection										
Front cover close	-	-	IP20				IP20			
Front cover open	-	-	IP10				IP10			
Operating condition										
Ambient temperature	T_u	°C	-25 to +55				-25 to +55			
Operating condition	-	-	Continuous operation							
Mounting	-	-	vertical, horizontal							
Altitude	-	m	≤ 2000							
Pollution degree	-	-	3							
Overvoltage category	-	-	III				III			

Technical data (in accordance with IEC/EN 60947-3 and VDE 0660, part 107)										
Technical Specifications			HVL-B 2				HVL-B 3			
Technical Characteristics										
Rated operational voltage	U_e	V	500 AC	690 AC	220 DC	440 DC	500 AC	690 AC	220 DC	440 DC
Rated operational current	I_e	A	400	315	400	315	630	500	630	500
Rated frequency	-	Hz	40-60	40-60	-	-	40-60	40-60	-	-
Rated insulation voltage	U_i	V	750 AC				750 AC			
Total power loss (without fuse)	P_v	W	27	16,7	18	11,2	52	32,8	34,6	21,8
Utilisation category	-	-	AC22B	AC22B	DC22B	DC21B	AC22B	AC22B	DC22B	DC21B
Fuse links										
Size - DIN 43 620	-	-	2				3			
Max. rated current (gG/gL)	I_n	A	400	315	400	315	630	500	630	500
Max. permissible power lose per fuse link	P_v	W	34				48			
Screw	-	-	M10				M10			
Torque	M_a	Nm	30-35				30-35			
V-clip	-	mm ²	25-240				25-240			
Torque	M_a	Nm	23				23			
Protection										
Front cover close	-	-	IP20				IP20			
Front cover open	-	-	IP10				IP10			
Operating condition										
Ambient temperature	T_u	°C	-25 to +55				-25 to +55			
Operating condition	-	-	Continuous operation							
Mounting	-	-	vertical, horizontal							
Altitude	-	m	≤ 2000							
Pollution degree	-	-	3							
Overvoltage category	-	-	III				III			

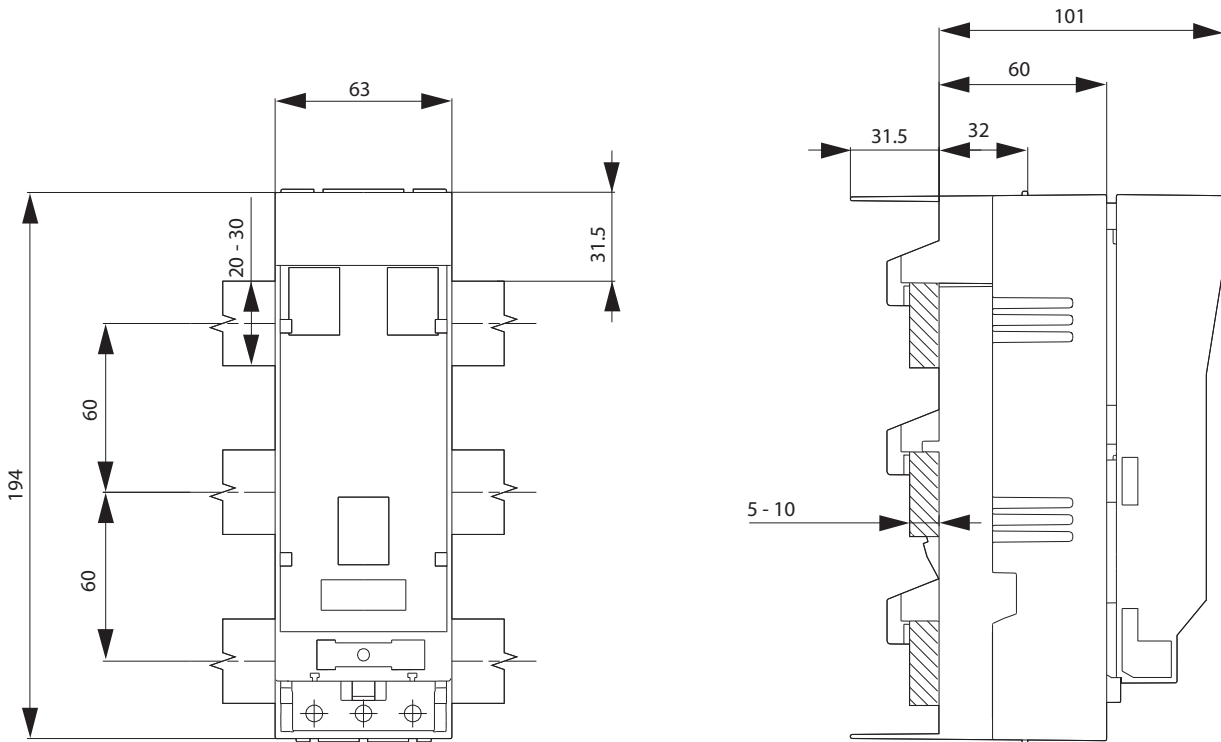

HVL-B 000 3p F57-5

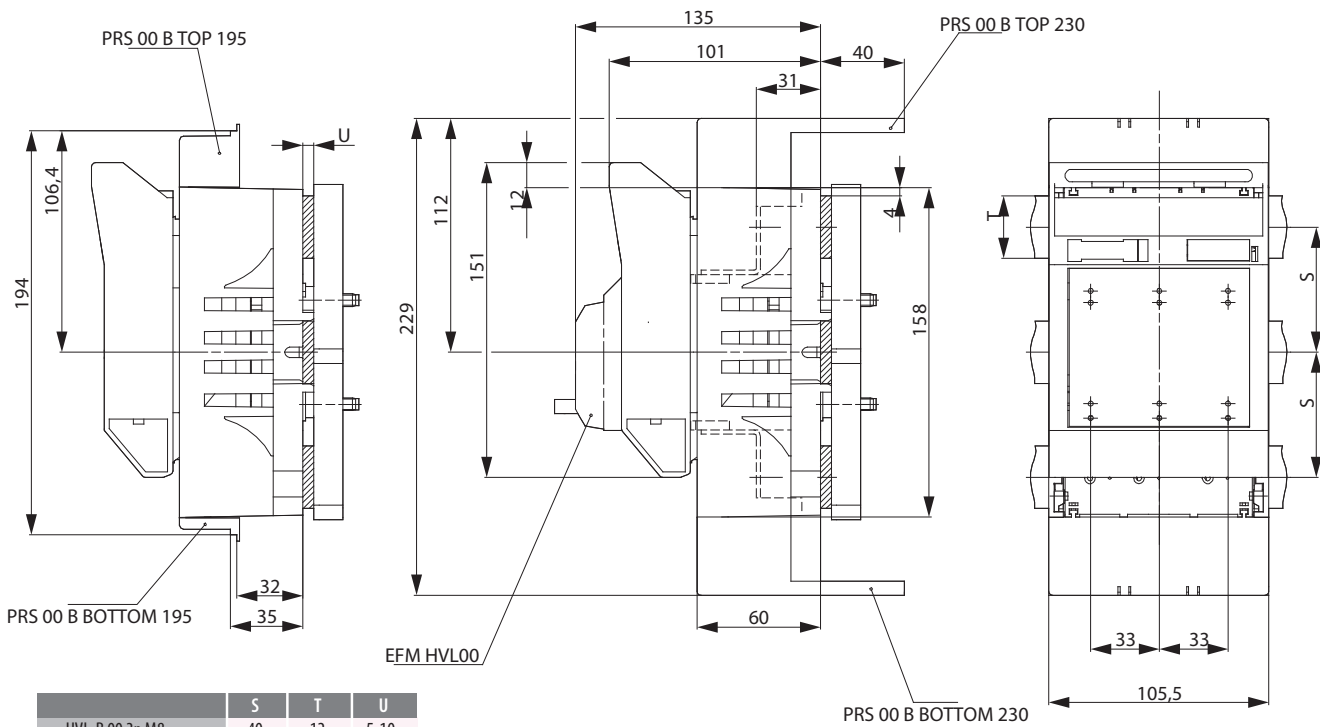

	S	T	U
HVL-B 00 3p M8	40	12	5-10
	50	20	5-15
	60	20-30	5-10

HVL-B 00 3p M8
HVL-B 00 3p F57

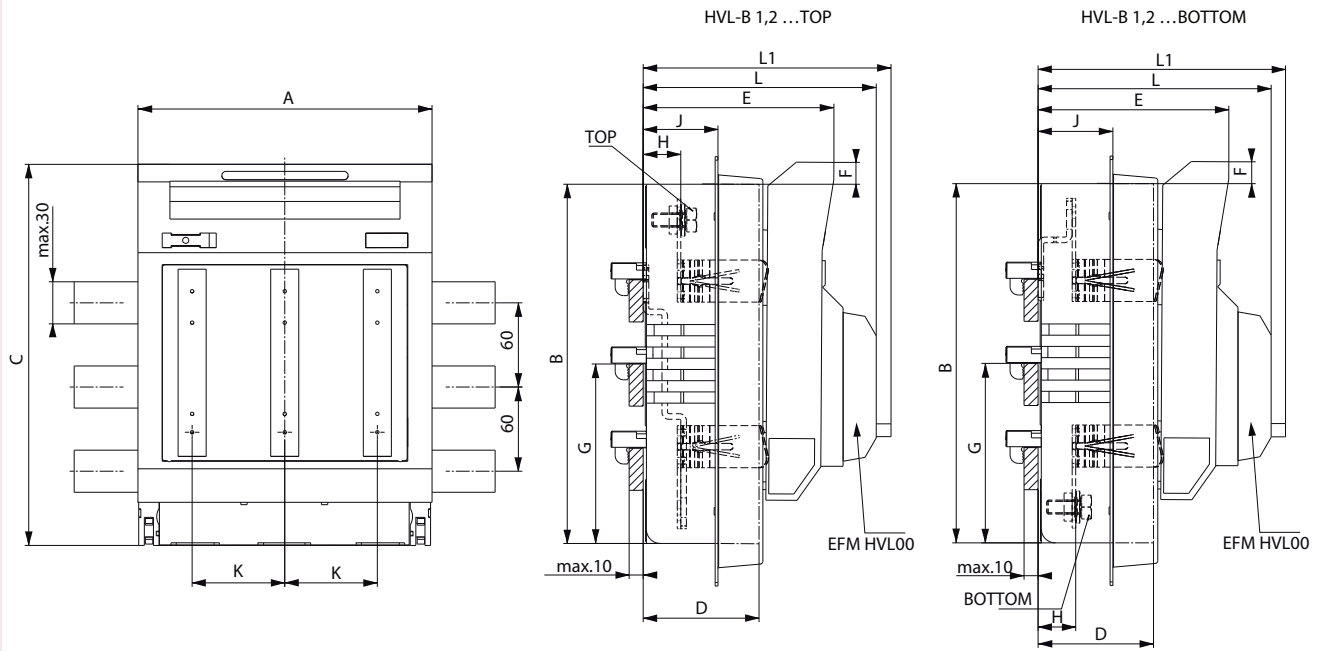



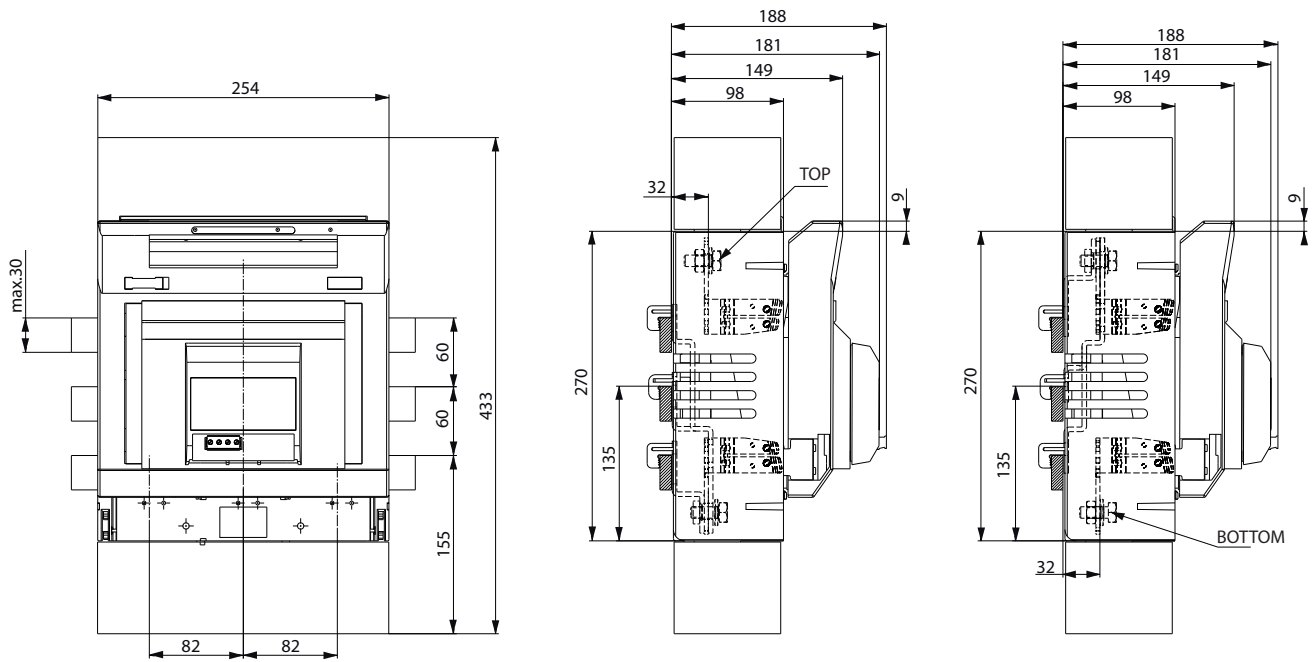

	A	B	C	D	E	F	G	H	J	K	L	L1
HVL-B 1 3p M10	184	230	247	69	121	17	116	27	55	58	152	162
HVL-B 2 3p M10	210	256	272	83	135	17	128	27	55	66	166	176

HVL-B 1 3p M10 TOP, HVL-B 1 3p M10 BOTTOM
 HVL-B 2 3p M10 TOP, HVL-B 2 3p M10 BOTTOM



HVL-B 3 3p M10 TOP, HVL-B 3 3p M10 BOTTOM

Terminal type	Type	Tightening torque	Clamping range	Size flat strip
 Screw terminal M8	F-M8x16	12 - 15 Nm	Cable lugs acc. to DIN 46234 and 46235	
 Clip terminal	S00	2,6 Nm	1,5 - 70 mm ² Cu	Busbars max. 9x8 flexible flat strip max. 6x9x0,8
 Prism clamp	P0070	2,6 Nm	10 - 70 mm ² Al/Cu	
 Elevator terminal	F57	2,6 Nm	1,5 - 70 mm ² Cu	

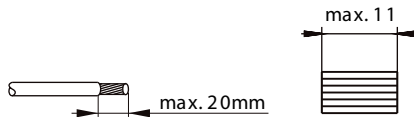

Technical data (in accordance with IEC/EN 60947-3, VDE 0636 part 301)

Technical Specifications			DVL-60/183
Electrical characteristics			
Rated operating voltage	U_e	V	400 AC
Rated operating current	I_e	A	63
Conv. Thermal current with fuse links	I_{th}	A	63
Rated frequency	–	Hz	40-60
Rated insulating voltage	U_i	V	400 AC
Rated conditional short-circuit current	–	kA _{eff}	50
Utilisation category	–	–	AC-23B
Rated making capacity	–	A	630
Rated breaking capacity	–	A	630
Rated impulse voltage	U_{imp}	kV	8
Electrical lifetime (switching cycles)	–	–	300
Total power dissipation (without fuse)	P_v	W	8
Fuselinks			
Size in according to DIN 49522, 49515	–	–	D01, D02
Max. rated current (gl/gG)	I_n	A	63
Max. permissible power dissipation (without fuse)	P_v	W	55
Cable terminal			
Mechanical lifetime (switching cycles)	–	–	1700
Busbar spacing (only 3-pole)	–	mm	60
Busbar thickness	–	mm	5 & 10
Busbar width	–	mm	20 & 30
Cable terminal			
Terminal, clamping range"	–	mm ²	0,75-25
Degree of protection			
Frontside, operating state	–	–	IP20
Front cover open	–	–	IP10
Degree of protection			
Umgebungstemperatur 1)/Ambient temperature 1)	T_u	°C	-25 ... 55
Bemessungsbetriebsart/Rated operating mode	–	–	Uninterrupted duty
Einbaulage/Mounting position	–	–	Vertical, horizontal
Höhenlage/Altitude	–	m	< 2000
Verschmutzungsgrad/Pollution degree	–	–	3
Überspannungskategorie/Overvoltage categorie	–	–	III

1) 35°C Normal temperature, 55°C with reduced current

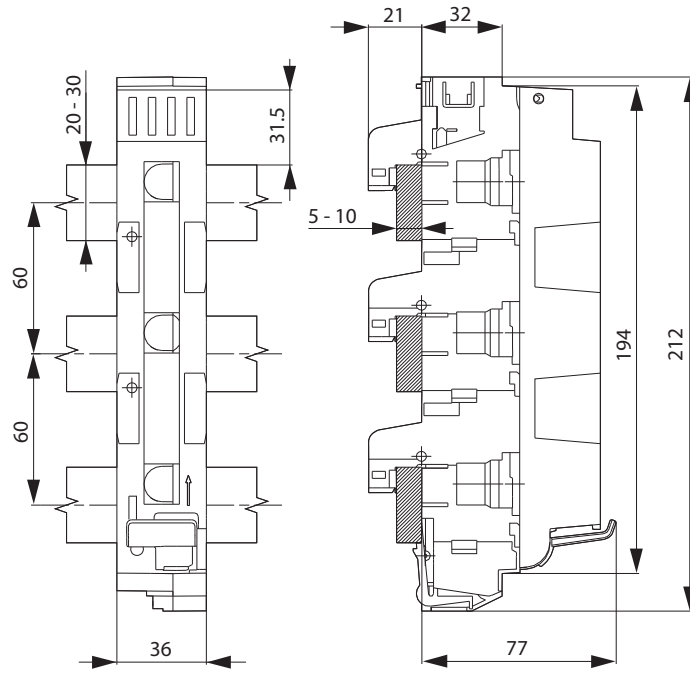

DVL-60/183

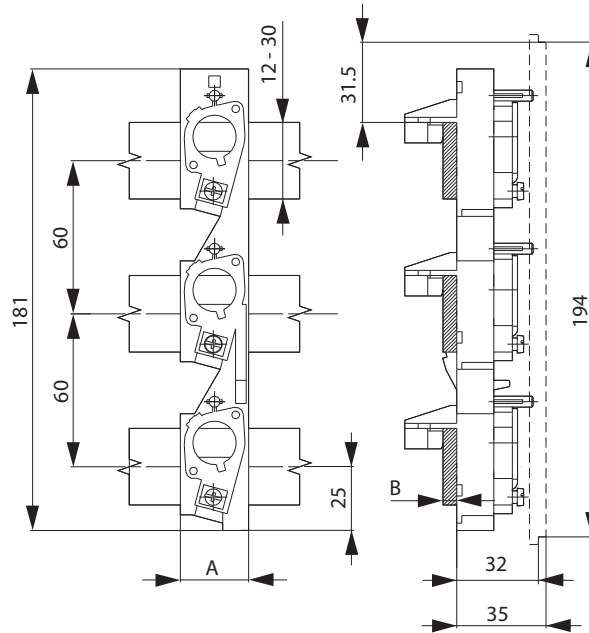

	A	B		A	B
RS60/183-5	27	5	RS60/183-10	27	10
RS60/273-5	45	5	RS60/273-10	45	10
RS60/333-5	54	5	RS60/333-10	54	10

PTV-B D

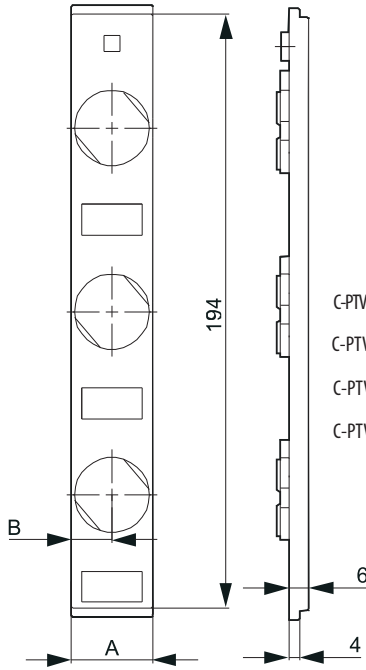

C-PTV-B...195

	A	B
C-PTV-BD02-27/183	27	13,5
C-PTV-B D02-36/183/195	36	22,5
C-PTV-B DII-45/273/195	45	22,5
C-PTV-B DIII-54/333/195	54	27

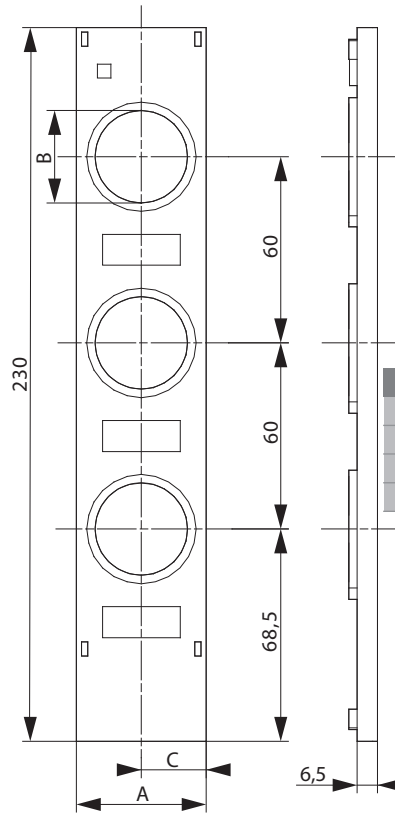

C-PTV-B...230

	A	B	C
A-RS183/230	27	21	13,5
A-RS183-36/230	36	21	13,5
A-RS273/230	45	30	22,5
A-RS333/230	54	36	27

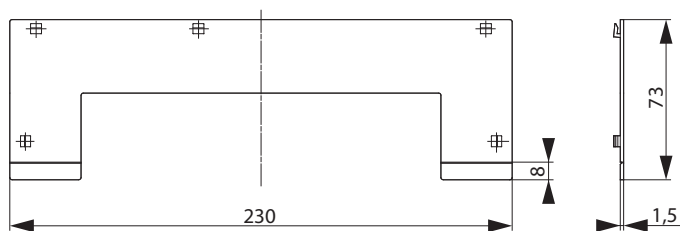

CL-PTV-B-D/230

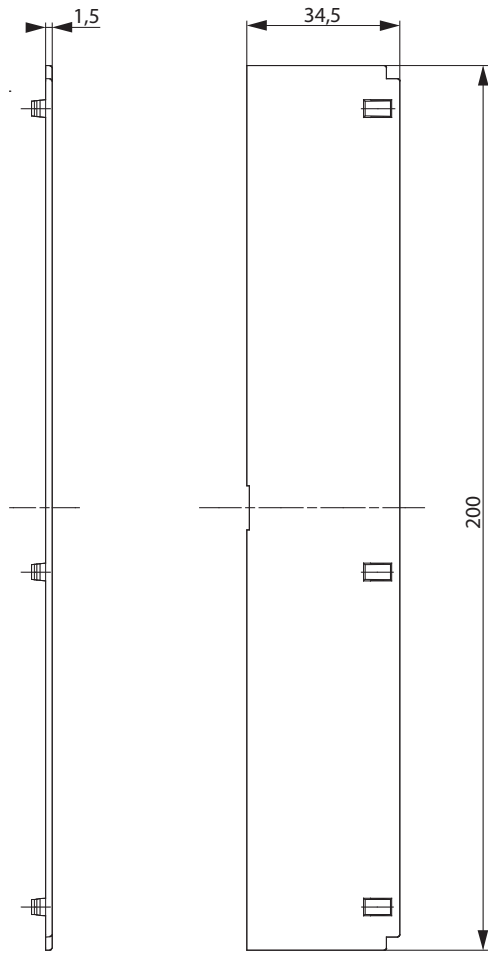

CL-PTV-B D/195

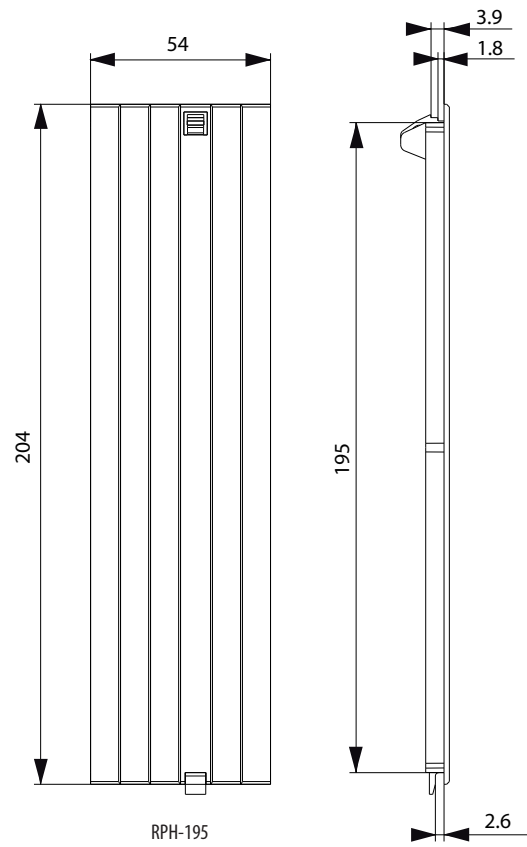

RPH-195

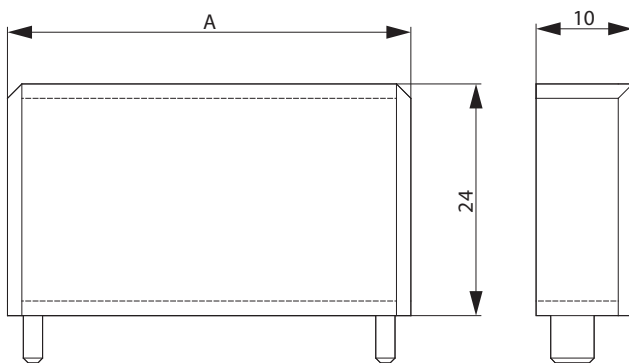

	A
RTP-D02-27/183	27
RTP-D02-36/183	36
RTP-DII-45/273	45
RTP-DIII-54/333	54

RTP-RL/

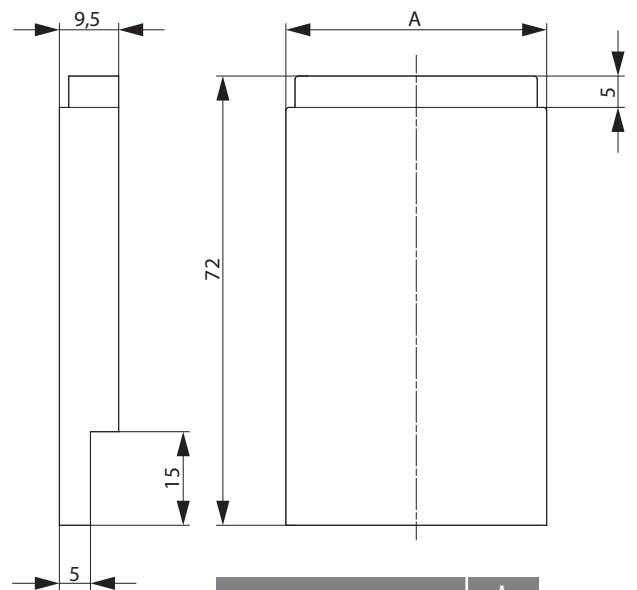

	A
RTP-D02-27/183	27
RTP-D02-36/183	36
RTP-DII-45/273	45
RTP-DIII-54/333	54

PRS-D.../183

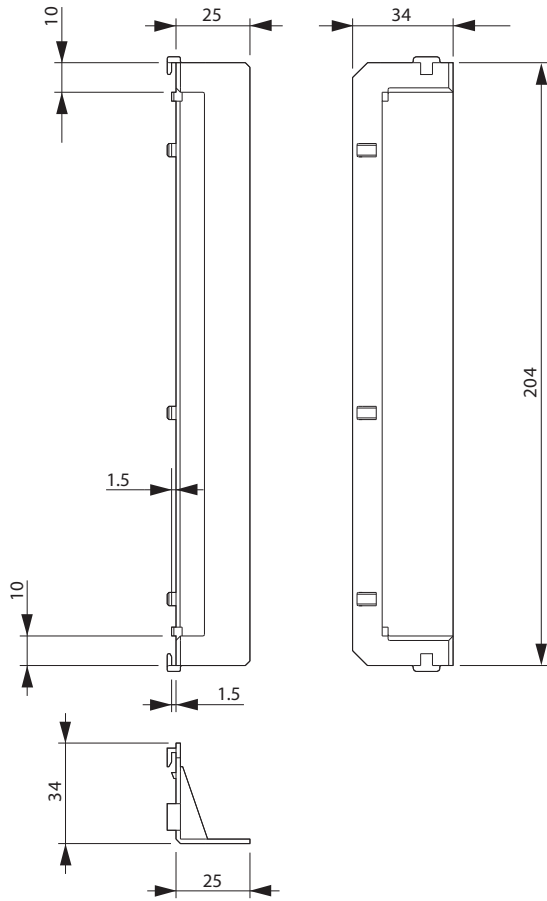

RTP-RL/230

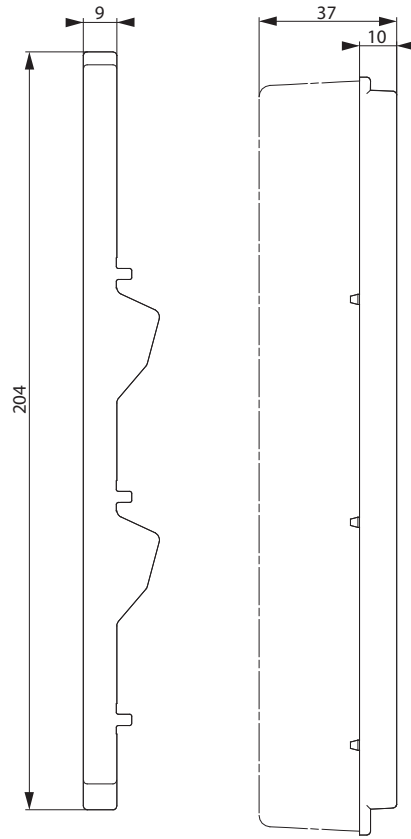

PRS-DVL

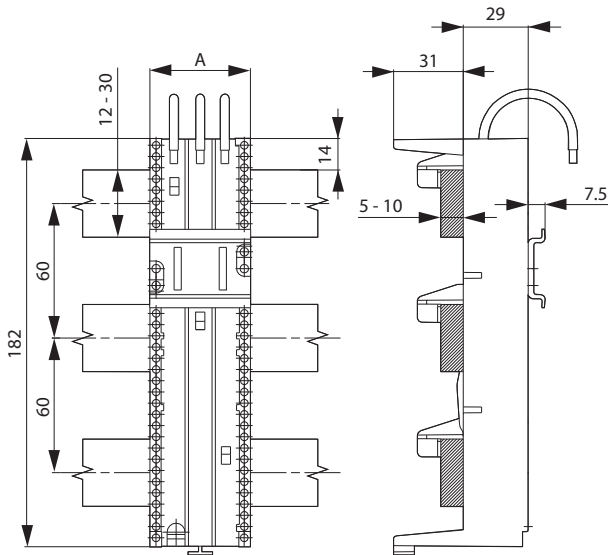

	A
GA-60/25/45	45
GA-60/32/108	108
GA-60/32/54	54
GA-60/32/63	63
GA-60/32/72	72
GA-60/32/81	81

	A
GA-60/63/108	108
GA-60/63/54	54
GA-60/63/63	63
GA-60/63/72	72
GA-60/63/81	81

DA-60/25/..., DA-60/32/..., DA-60/63/...