

Special Purpose Fuses

Multimeter and metering fuses	5
DC fuses, fuse bases and disconnectors	9
Mining fuses	19
Safe Work Fuses	25
Fuses for TVSS products protection	26
Fuses for railway applications	28
Battery Protection Fuses	42
Fuel Cell Protection Fuses	54

PROTECTION OF SPECIAL APPLICATIONS



Contents

MULTIMETER Fuse Links

CH gR SE (SPECIAL EDITION)

Fuse Link gG NV/NH 400V a.c. metering

Fuse Link gTr NV/NH 400V a.c. metering

DC Fuses:

NH DC 80 V - Telecom fuse

NH DC 250 V

NH DC 440 V

NH DC 1000 V aR

NV Telecom fuse disconnectors

Fuse base PK00 1000V a.c. M8-M8

Fuse base PK1 and PK3 DC

Fuse base U1-1 1000V

Fuse base PK XL

Fuse disconnectors TL1-1/9/1000V

Mining Fuses:

Fuse-link aM NV/NH 1000V a.c.

Fuse-link gB NV/NH 00 1000V a.c.

Fuse-link gG NV/NH 1200 V a.c.

Safe work Fuses

Fuses for TVSS products protection:

CH SRF class II

CH SRF 25kA class I

CH SRF class II - DC

Fuses for railway applications:

NH1S/394/DC 4000V aR-fuse link

NH2 S/394/ DC 4000V aR - fuse link

NH1 /350/DC 4000V aR-fuse link

NH1 /130/DC 1000V gR - fuse link

Fuses for high-voltage switchgear

Battery Protection Fuses:

CH 10x38 BATTERY Fuse link 550V d.c.

CH 10x38 BATTERY Fuse link 800V d.c.

CH 14x51 BATTERY Fuse link 800V d.c.

NH BATTERY fuse link 80V d.c.

Fuses for protection of forklift batteries TRB

NH BATTERY fuse link 550V d.c.

NH BATTERY fuse link 700V d.c.

NH BATTERY fuse link 800V d.c.

Fuel Cell Fuses

MULTIMETER Fuse Links

General characteristics	
Rated voltage	1000V a.c./d.c.
Breaking capacity	30kA a.c./d.c.
Characteristics	gR
Standards	IEC 60269-4, UL 248-1, UL 248-13
UL certificate	Nr. E331260
Application	Multimeter fused

CH10 MULTI					
Size	I_n [A]	Code No. standard indicator	Power dissipation [W]	Packaging [pcs]	Weight [g]
10x38	2	002625400	0,9	10/500	10
	4	002625401	1,2		
	6	002625402	1,6		
	8	002625403	1,8		
	10	002625404	2,1		
	12	002625405	1,7		
	16	002625406	2,3		
	20	002625407	3,15		

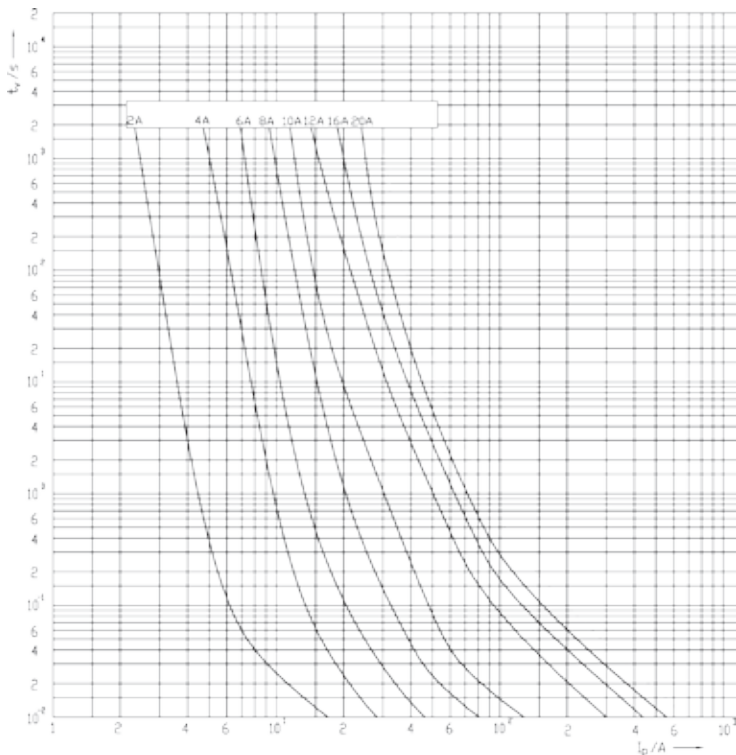
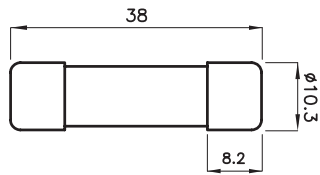

CH gR SE (SPECIAL EDITION)

General characteristics	
Rated voltage	690V a.c.
Breaking capacity	100kA AC
Characteristic	gR, according to IEC 60269-4
Application	Fuses are fast acting, full range. Used in protection of the inverters, variable speed drives. Excellent cycling load capability (70 000 current cycling test).

CH 10x38gR SE 690V									
Size	I_n [A]	Code Number "standard contacts"	Code Number "type SU contacts"	Pre-arcing Joule integral [A ² s] L/R=10ms	Operating Joule integral [A ² s] L/R=10ms	Power dissipation [0,8 x I _n] P _d [W]	Power dissipation [1 x I _n] P _d [W]	Packaging [pcs]	Weight [g]
10x38	16	002625046	002625048	32	166	1,6	2,8	10/500 SU:10/380	10/12
	20	002625047	002625049	80	340	1,7	2,9		

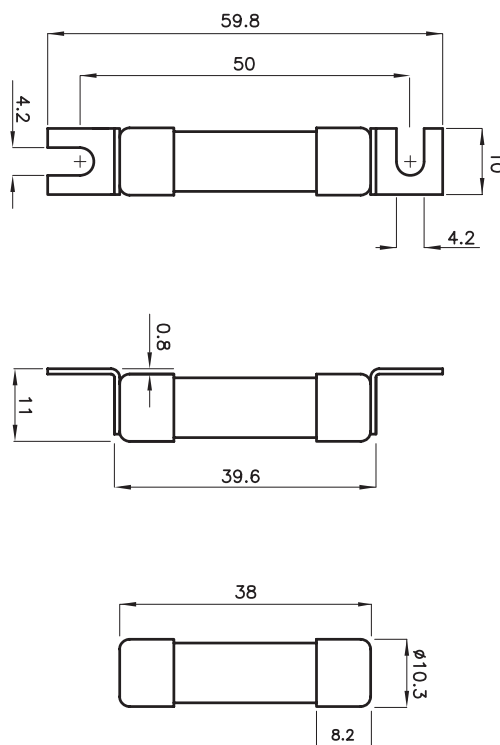
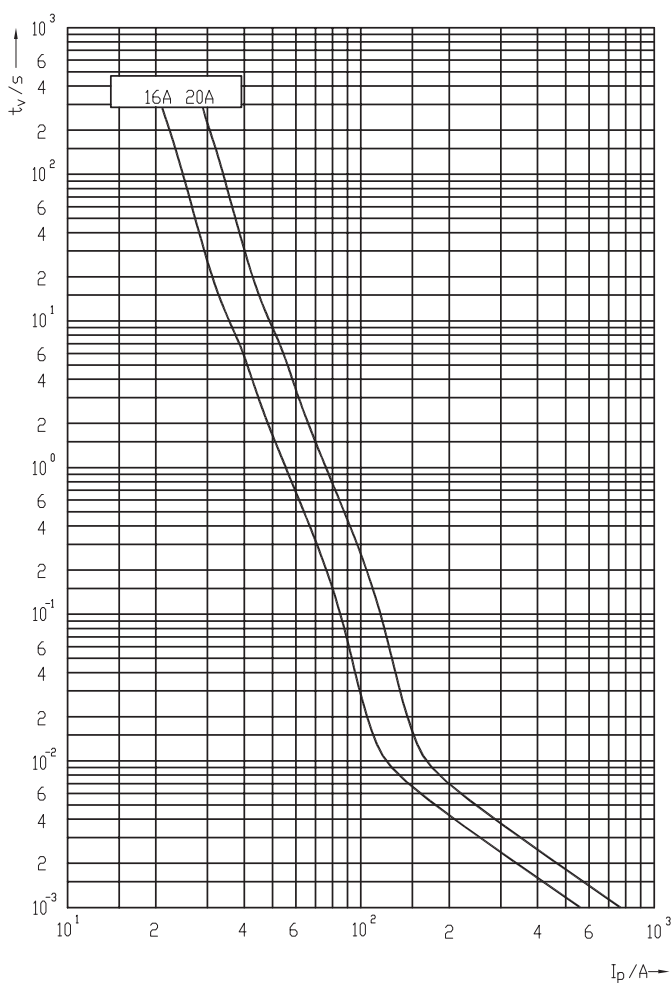

Simulating current of motor start
70.000 current cycle test at $T_{amb} = 70^{\circ}C$
 $I_N = 6,5A$
Max. permissible motor rated current

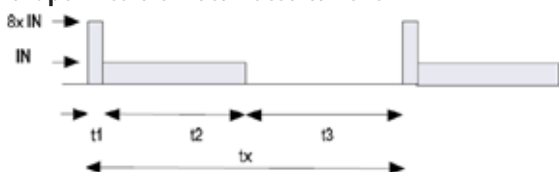

Fuse Link gG NV/NH 400V a.c. metering

General characteristics	
Rated voltage	400V a.c.
Breaking capacity	50kA a.c.
Standards	IEC EN 60269-1
Characteristic	gG
Application	As metering fuse with strip fuse switch disconnecter and fuse switch disconnecter

NV/NH 400V a.c.					
Size	I _n [A]	standard indicator	Power dissipation [W]	Packaging [pcs]	Weight [g]
1	80	004113835	5,2	1/26	500
	100	004113836	6,2		
	125	004113837	7,9		
	160	004113838	9		
	200	004113839	12		
	250	004113840	17		
2	80	004113842	5,2	1/16	600
	100	004113843	6,2		
	125	004113844	7,9		
	160	004113845	9		
	200	004113846	12		
	250	004113847	17		
	315	004113848	20		
3	200	004113851	12	1/9	1000
	250	004113852	17		
	315	004113853	20		
	400	004113854	24		
	500	004113855	27		
4a	630	004113856	32	1	2000
	800	004113858	51		
	1000	004113859	61		
	1250	004113860	72		
		004113861	90		



Fuse Link gTr NV/NH 400V a.c. metering

General characteristics	
Rated voltage	400V a.c.
Breaking capacity	25kA a.c.
Standards	IEC EN 60269-1
Characteristic	gTr
Application	As metering fuse with strip fuse switch disconnecter and fuse switch disconnecter

NV/NH 400V a.c.						
Size	Nominal transformer power [kVA]	I_n [A]	standard indicator	Power dissipation [W]	Packaging [pcs]	Weight [g]
1	100	144	004113865	11	1/26	500
	125	180	004113866	13		
	160	231	004113867	17		
2	100	144	004113872	11	1/16	600
	125	180	004113873	13		
	160	231	004113874	17		
	200	289	004113875	20		
	250	361	004113876	25		
	125	180	004113881	13		
3	160	231	004113882	17	1/9	1000
	200	289	004113883	20		
	250	361	004113884	25		
	315	455	004113885	32		
	400	577	004113886	40		
	250	361	004113890	25		
4a	315	455	004113891	32	1	2000
	400	577	004113892	40		
	500	722	004113893	54		
	630	909	004113894	71		
	800	1155	004113895	91		
	1000	1443	004113896	110		

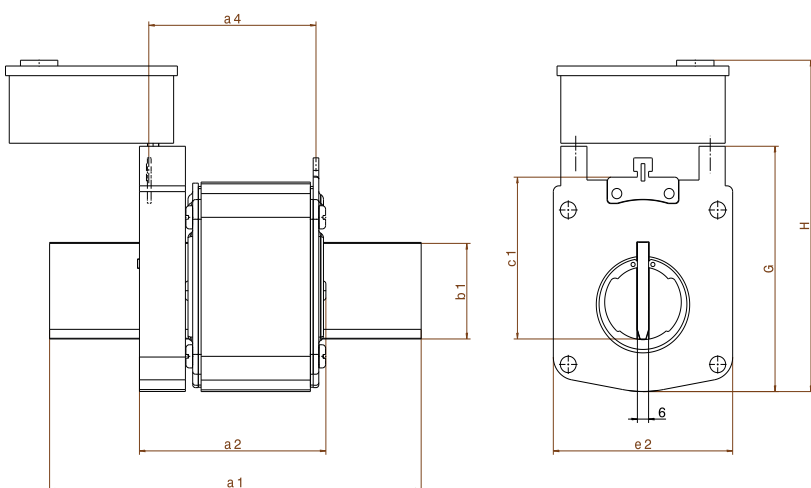

Size	dimensions [mm]							
	a1	b1	c1	e1	G	H	a2	a4
1	135	24	40	52	67	112	75	65
2	150	30	48	60	74	119	75	65
3	150	32	60	74	89	134	75	65
4a	200	50	85	96	127	200	100	87

Telecom Fuses

FUSES FOR DC (Direct Current) APPLICATIONS -

ETI solution for TELECOM Power Supply Circuits

ETI d.d. developed specially designed fuse-links for short circuit protection of d.c. telecom power supplies. They are typically installed into rectifier outputs, battery feeders or d.c. power distribution for protection of the load circuits.

All their characteristics are optimized to correspond to the operating conditions of telecom power supply equipment. Power dissipations and switching voltage provide optimal function and protection of telecom power supplies. The ETI TELECOM NH00 fuse-link is a high breaking capacity current limiting fuse-link with pure silver, age-resistant melting element.

NH DC 80 V - Telecom fuse

General characteristics	
Rated voltage	80 V d.c. (L/R = 20 ms)
Breaking capacity	25 kA d.c.
Standards	IEC 60269-1
Application	Fuse-link for battery and UPS protection.

NH DC 80 V - Telecom fuse						
Size	I _n [A]	Code No.		Power dissipation [W]	Packaging [pcs]	Weight [g]
		standard indicator	striker indicator			
00	160	004110106	004110101	9,0	3/90	173
	200	004110120	-	10,5		
	250	004110107	004110102	12,5		
	400	004110108	004110103	17,5		
	630	004110109	004110104	28,0		
	800	004110110	004110105	37,5		



Special Purpose Fuses

Time-current characteristics

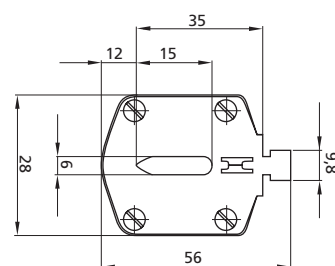
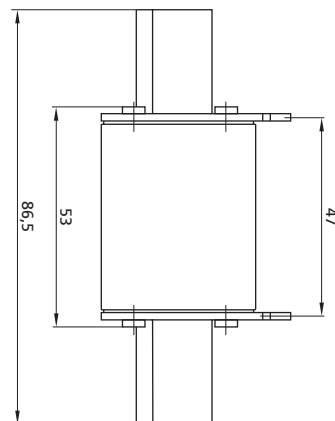
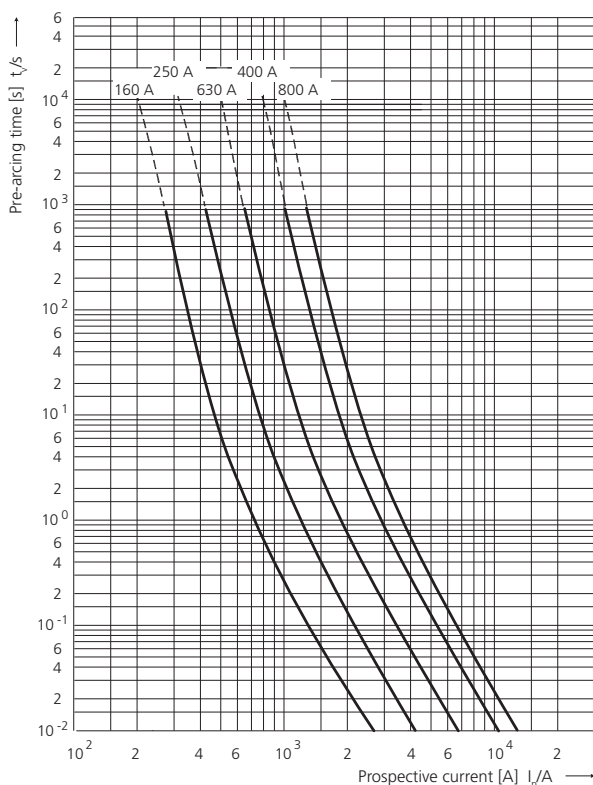

NH DC 250 V

General characteristics

Rated voltage	250 V d.c. (L/R = 20 ms)
Breaking capacity	25 kA d.c.
Standards	IEC 60269-2
Application	Fuse-link for DC application.

NH DC 250 V

Size	I _n [A]	Code No.		Power dissipation [W]	Packaging [pcs]	Weight [g]
		standard indicator	striker indicator			
00	63	004110130	004110135	7,5	3	654
	100	004110131	004110136	8,6		
	160	004110132	004110137	13,8		
	200	004110140	004110138	18,5		
	250	004110133	004110139	21,2		
	315	004110134	004110141	24,0		

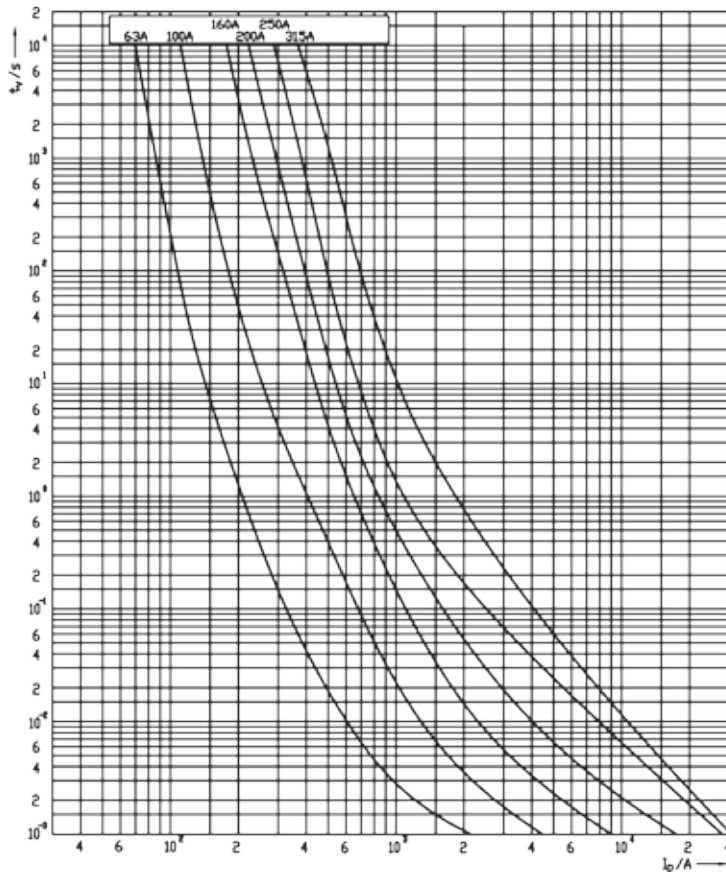
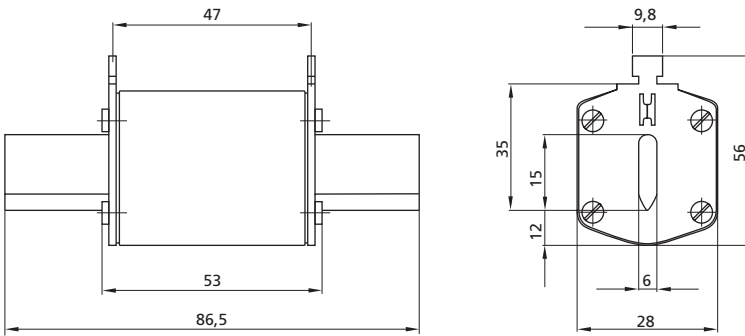

NH DC 440 V

General characteristics	
Rated voltage	440 V d.c. (L/R = 20 ms)
Breaking capacity	50 kA d.c.
Standards	IEC 60269-2
Application	Fuse-link for DC application.

NH DC 440 V								
I_n [A]	Code No.				Size	Max. power dissipation [W]	Packaging [pcs]	Weight [g]
	00 C	00	1 C	1				
20	004110200		004110220		00 C	7,2	3/120	125
25	004110201		004110221		00	15,1	3/90	173
32	004110202		004110222		1 C	21,9	3/45	233
40	004110203		004110223		1	31,3	3/24	430
50	004110204		004110224					
63		004110210	004110225					
80		004110211	004110226					
100		004110212	004110227					
125		004110213	004110228					
160		004110214	004110229					
200				004110230				
250				004110231				

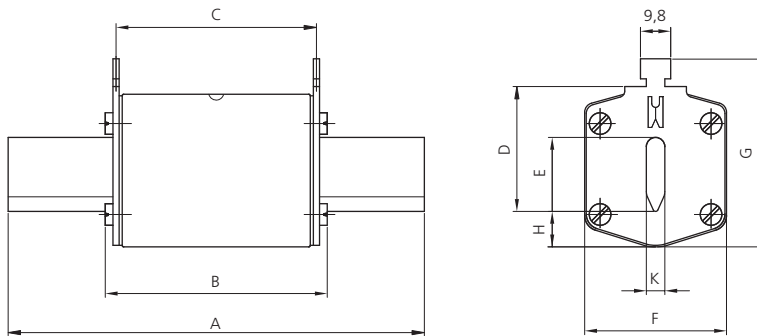

type	dimensions [mm]								
	A	B	C	D	E	F	G	H	K
00 C	79	53	47	35	15	21	52	7,5	6
00	79	53	47	35	15	28	56	12	6
1 C	135	68	65	40	15	28	61	12	6
1	135	72	65	40	20	46	65	14	6

Time-current characteristics

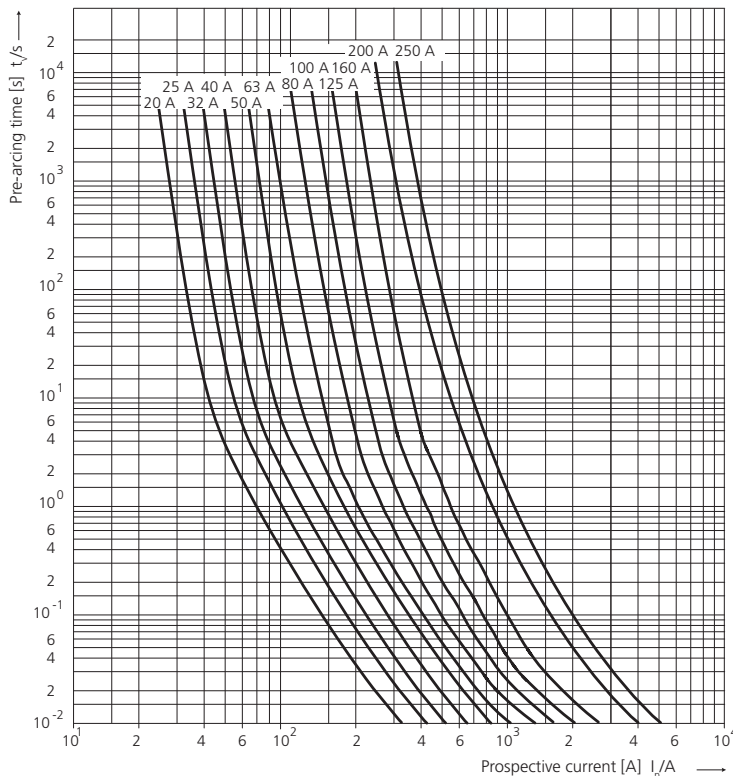

NH DC 1000 V aR



General characteristics	
Rated voltage	1000V d.c. (L/R=1ms)
Breaking capacity	30 kA d.c.
Standards	IEC 60269-4
Application	Fuse-link for DC application.

NH DC 1000 V aR							
Size	I_n [A]	Type with center trip indicator for microswitch MK	Power dissipation [W]	Pre-arcing Joule integral (I^2t) L/R=1ms	Operating Joule integral (I^2t) L/R=1ms	Packaging [pcs]	Weight [g]
3L	800	004305636	139	500.000	1.000.000	1	1500
	1000	004305637	154	900.000	1.600.000		
	1250	004305635	201	1.500.000	3.000.000		

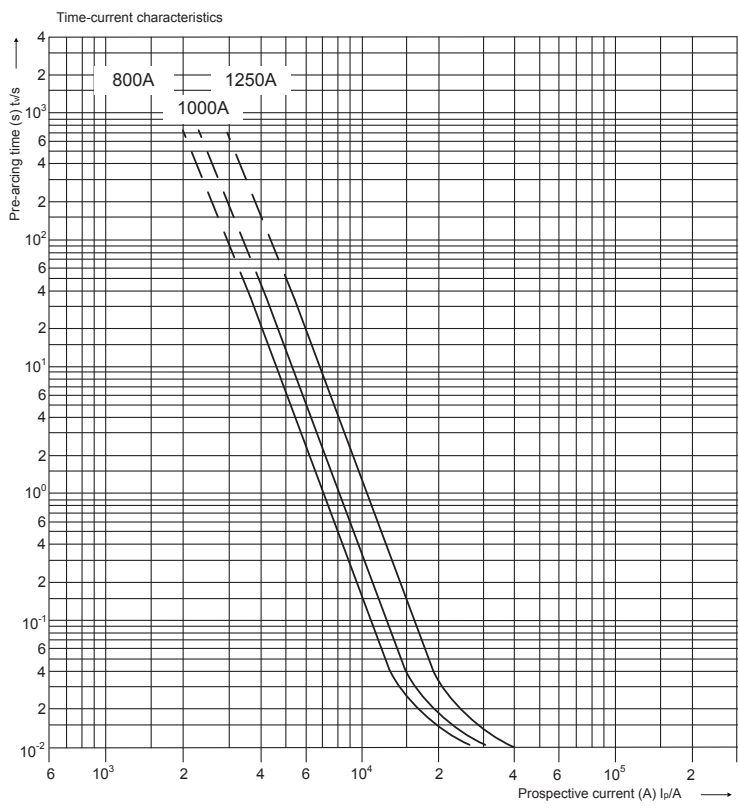
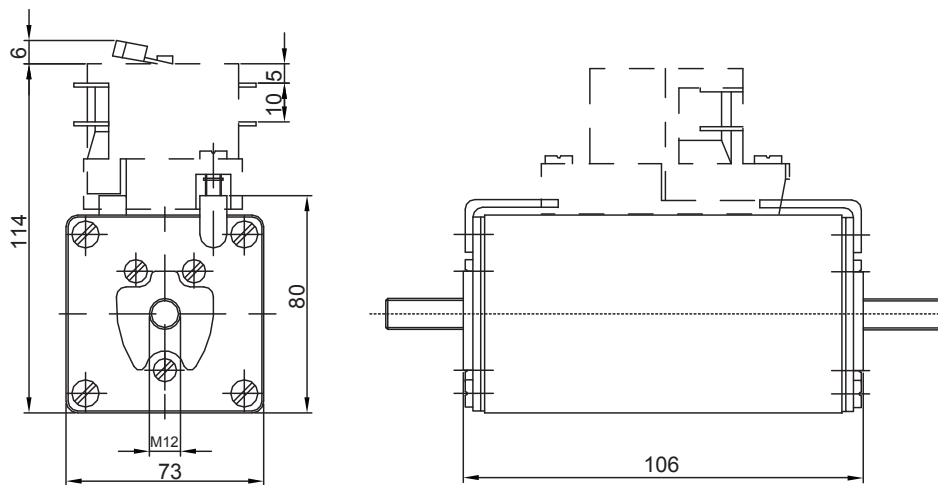

NV Telecom fuse disconnectors

NV Telecom fuse disconnectors	
type	Code No.
HVL 00 Telecom 1P M12-M12, front connection, for striker	001692660
HVL 00 Telecom 1P M12-M12, rear connection, for striker	001692661
HVL 00 Telecom 1P M12-M12, front connection	001692662
HVL 00 Telecom 1P M12-M12, rear connection	001692663

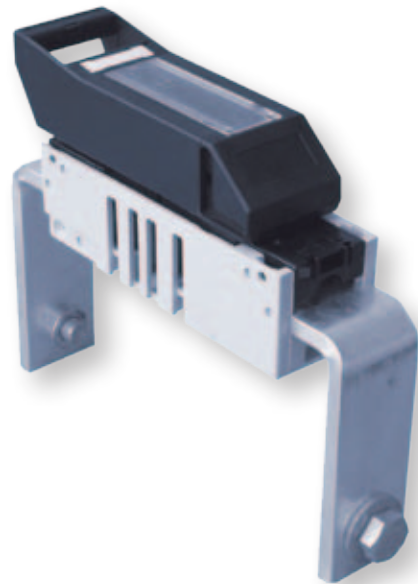

Technical data for NV Telecom fuse disconnectors				
Technical Specifications				HVL 00
Electrical Characteristics				
Rated conditional short-circuit current	-	kA_{eff}		50
Utilization category	I_e	A		DC 20-B/800 A
Rated impulse withstand voltage	U_{imp}	kV		8
Operating cycles with current	-	-		100
Total power loss at I_n (without TM)	O_v	W		44
Fuse links				
Size to DIN 43620	-	-		00
Max. rated current (gG)	I_n	A		800
Mechanical characteristics				
Operating cycles without current	-	-		500
Weight	-	kg		0,75
Cable connection				
Flat terminal	Bolt diameter	-	-	s. drawings
	Cable lug (DIN 43620)	-	mm ²	240
	Flat bar	-	mm	30x10
	Tightening torque	M_n	Nm	30-35
Type of protection				
Front side	Operational state	-	-	IP 20
Device fitted	Front cover open	-	-	IP 10
Operating conditions				
Ambient temperature	T_u	°C		-25 to +55
Rated operating mode	-	-		Continuous operation
Actuation	-	-		dependent manual operation
Mounting position	-	-		vertical, horizontal
Altitude	-	m		up to 2000
Pollution degree	-	-		3
Overvoltage category	-	-		III

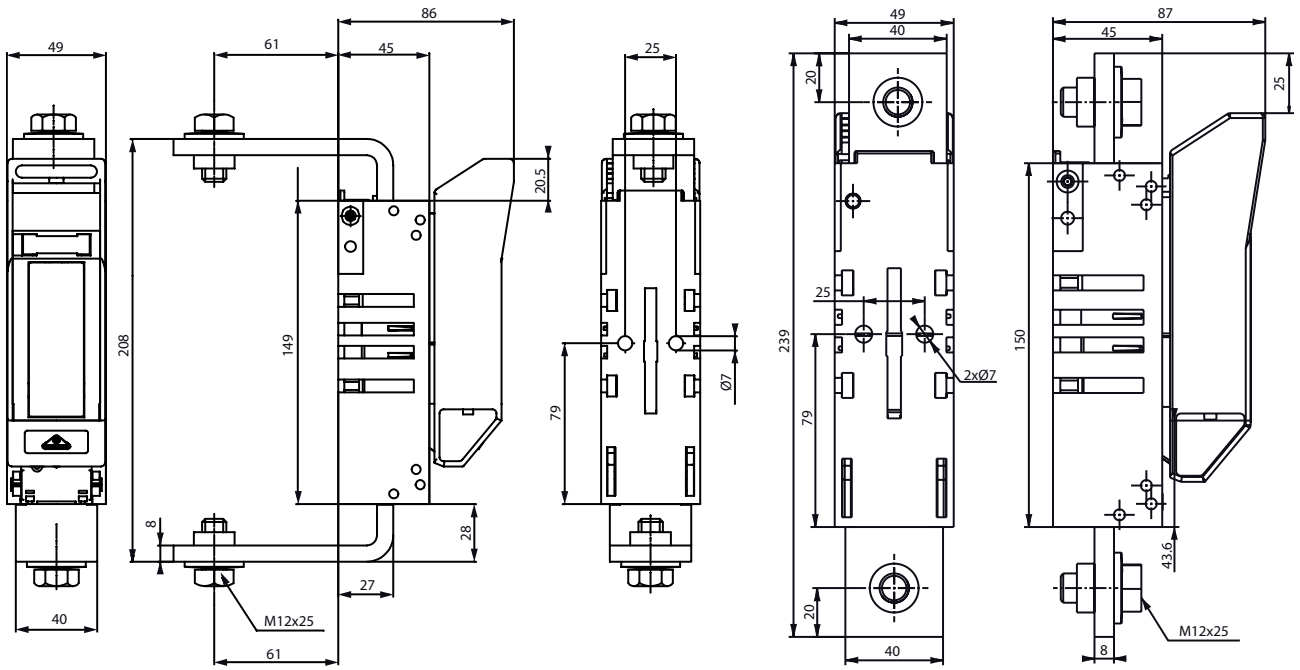

Fuse base PK00 1000V a.c. M8-M8

General characteristics	
Rated voltage	1000V a.c.
Rated current	160A
Insulation class	C-VDE 0110
Standards	EN 60269, IEC 60269, DIN VDE 0636, DIN 43620, DIN 43623

Fuse base PK00 1000V M8-M8				
Type	I _n [A]	Code No.	Weight [g]	Packaging [pcs]
PK00 1000Va.c. M8-M8	160	004132026	190	3/120

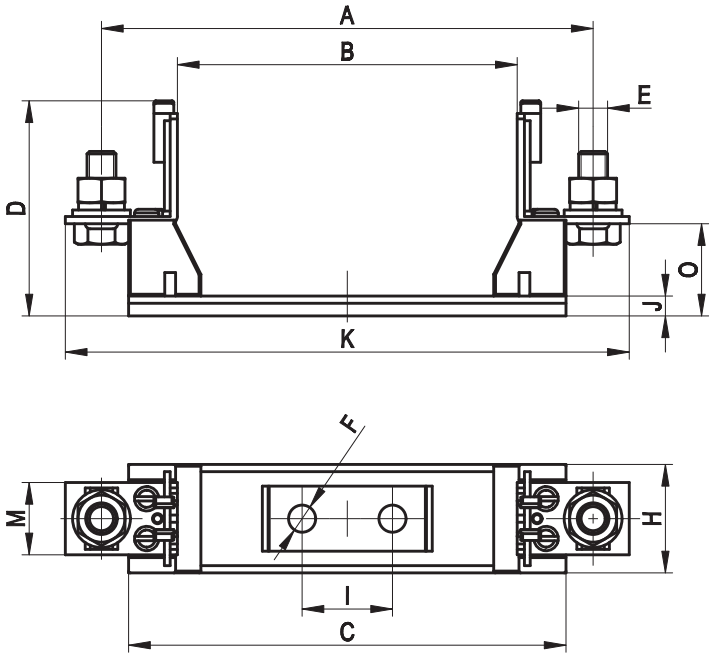

Type	Dimensions [mm]											
	A	B	C	D	E	F	H	I	J	K	M	O
PK00 1000V M8-M8	136	94	121	58,5	M8	7,5	30	25	4,5	156	20	25,5

Fuse base PK1 and PK3 DC

General characteristics	
Rated voltage	1000V d.c.
Rated current	250A
Insulation class	C-VDE 0110
Standards	EN 60269, IEC 60269, DIN VDE 0636, DIN 43620, DIN 43623

Fuse base PK1				
Type	I _n [A]	Code No.	Weight [g]	Packaging [pcs]
PK1 DC	250	004122025	598	3/42
PK3 DC	400	004122023	1202	3/24

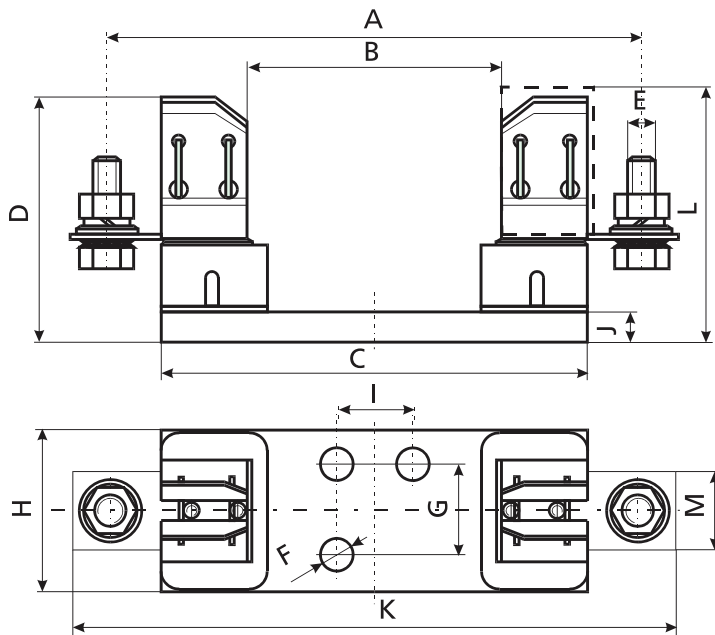

Type	Dimensions [mm]											
	A	B	C	D	E	F	G	H	I	J	K	M
PK1 DC	175	80	141	81	M10	Ø10,5	30	55	25	10	200	26
PK3 DC	210	80	166	104	M12	Ø10,5	30	65	25	10	240	30



Fuse base U1-1 1000V

General characteristics		
Rated voltage	1000V d.c.	
Rated current	160A	
Conv. free air thermal current with fuse-links	160A	
Conv. free air thermal current with solid links	325A	
Max. permis. power dissipation per fuse-link	31W	
Cable terminal - Flat terminal	Screw	M10
	Cable lug (DIN 46235)	25-150 mm ²
	Flat termination	30x10 mmx-mm
	Rated torque	30-35 Nm

Fuse base U1-1 1000V					
Type	I _n [A]	Code No.	Max. Connection (mm ²)	Weight [g]	Packaging [pcs]
U1-1 1000V	160	004122035	150	387	1

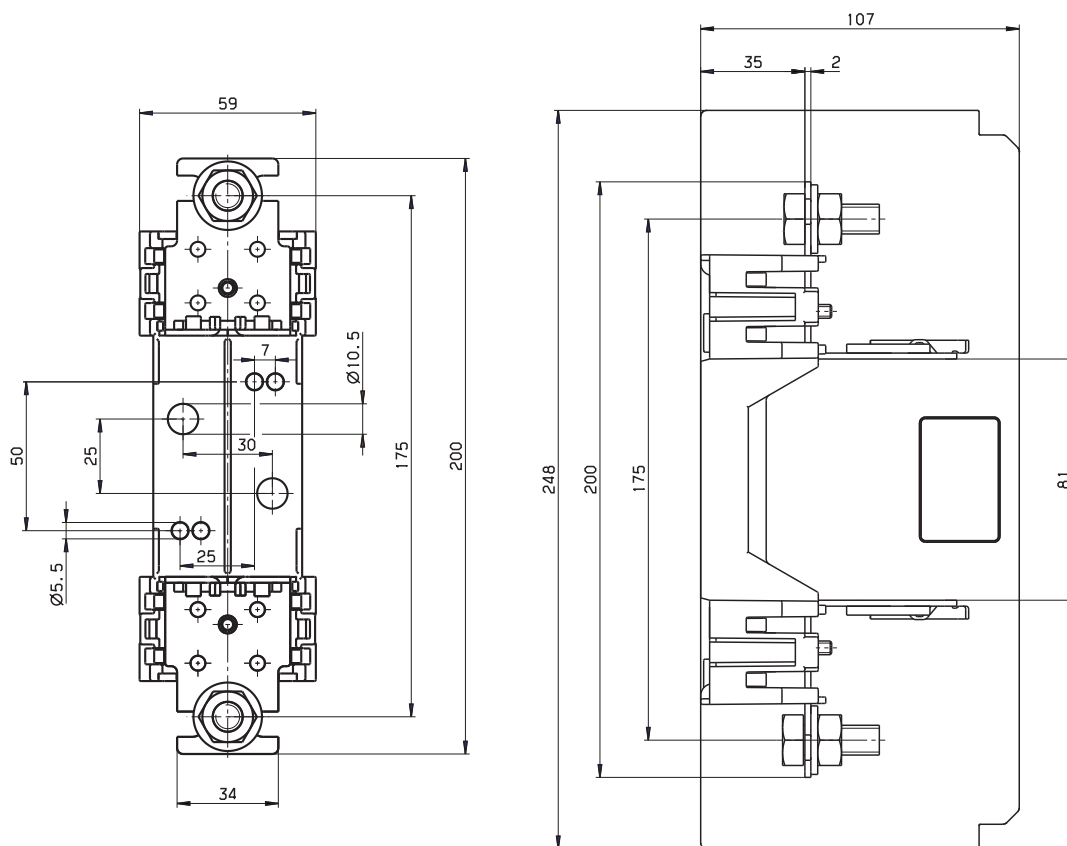

Fuse base PK XL

General characteristics	
Rated voltage	1200V a.c./d.c.
Rated current	250A, 400A, 630A
Insulation class	C-VDE 0110
Standards	EN 60269, IEC60269, DIN VDE 0636, DIN 43620, DIN 43623

Fuse base PK XL		
Type	I _n [A]	Code No.
PK1 XL	250	004132017
PK2 XL	400	004132019
PK3 L	630	004132023

Fuse base PKI XL - insulated contact		
Type	I _n [A]	Code No.
PKI1 XL	250	004132018
PKI2 XL	400	004132025
PKI3 L	630	004132024

Used only in combination with ETI fuse links!

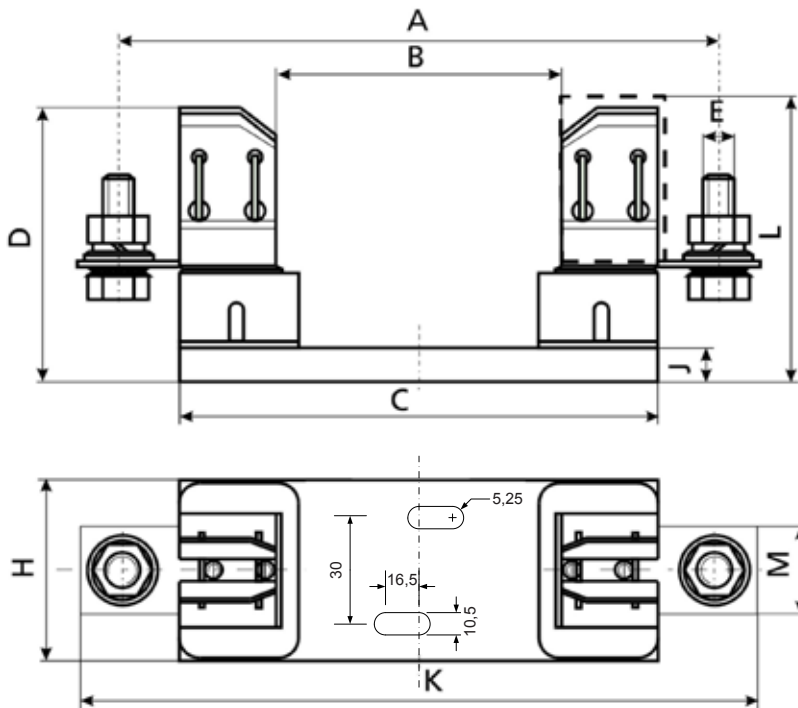

Size	Dimensions [mm]									
	A	B	C	D	E	H	J	K	L	M
PK1XL	235	140	201	81	M10	55	10	260	88	26
PK2XL	260	140	226	102	M10	65	10	285	99	30
PK3L	270	140	226	102	M12	65	10	300	99	30

Fuse disconnecter TL1-1/9/1000V

General characteristics		
Number of poles		1
Rated voltage		1000V d.c.
Rated current		160A
Conv. free air thermal current with fuse-links		160A
Utilization category		DC-20B
Fuse-links	Size to DIN 43620	1
	Max. rated current (gL/gG)	160A
	Max. permis. power loss per fuse-link	25W
Cable terminal - Flat terminal	Screw	M10
	Cable lug (DIN 46235)	25-240 mm ²
	Flat termination	30x10 mm
	Rated torque	30-35 Nm
Type of protection - front side, device fitted		IP20, IP10
Operating conditions	Ambient temperature*	-25 to +55
	Rated operating mode	Cont. operation
	Actuation	Dependent manual actuation
	Mounting position	Vertical, horizontal
	Altitude	up to 2000 m
	Pollution degree	3
	Overvoltage category	III



*35°C normal temperature, 55°C with reduced operating current

Fuse disconnecter TL1-1/9/1000V						
Type	I _n [A]	Code No.	Max. Connection (mm ²)	Terminal	Weight [g]	Packaging [pcs]
TL1-1/9/1000V	160	004122038	150	M10	1070	1

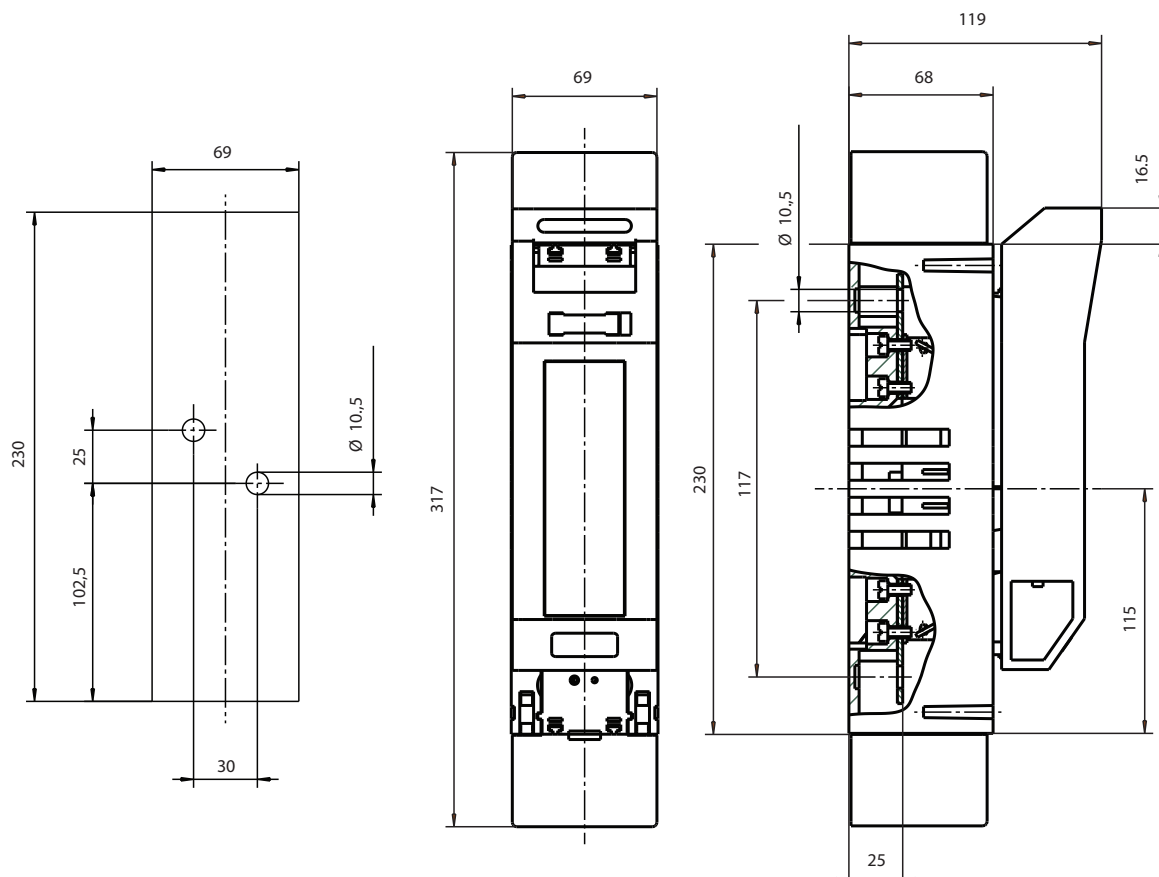

Fuse-link aM NV/NH 1000V a.c.

General characteristics	
Rated voltage	1000V a.c.
Breaking capacity	25kA a.c.
Standards	VDE 0636-2011
Characteristic	aM
Application	For equipment protection in mining industry. For relays, contactors and motors protection in case of short-circuit.

1000V a.c. aM								
Size	I _n [A]	Standard indicator	Pre-arcing Joule integral [A ² s]	Operating Joule integral [A ² s] at 635V	Operating Joule integral [A ² s] at 1100V	Power dissipation [W]	Weight [g]	Packaging [pcs]
1	50	004184432	7.000	23.000	40.000	13	530	1/8
	63	004184433	11.000	40.000	60.000	15		
	80	004184434	17.000	63.000	100.000	17		
	100	004184435	32.000	110.000	170.000	19		
	125	004184436	45.000	150.000	230.000	21		
	160	004184437	65.000	230.000	400.000	25		
	200	004184438	110.000	400.000	600.000	28		
3	200	004186434	110.000	400.000	600.000	28	1000	1/8
	250	004186435	180.000	650.000	1.000.000	31		
	315	004186436	340.000	1.400.000	2.000.000	41		
	400	004186437	500.000	2.000.000	3.000.000	50		
	425	004186438	550.000	2.150.000	3.300.000	53		
	500	004186439	700.000	2.500.000	4.000.000	60		

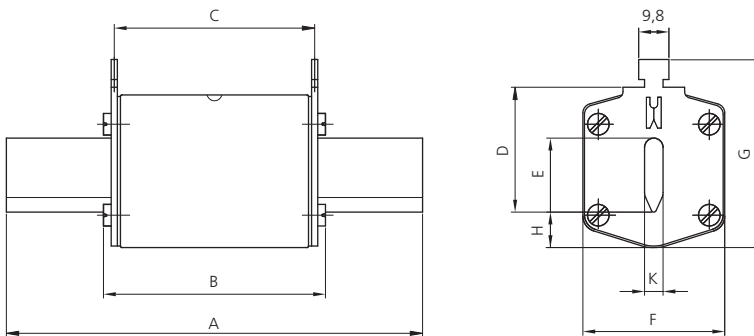

Size	Dimensions [mm]									
	A	B	C	D	E	F	G	H	K	
1	155	91	85	40	24	46	61	12	6	
3	170	91	85	60	32	64	84	13	6	

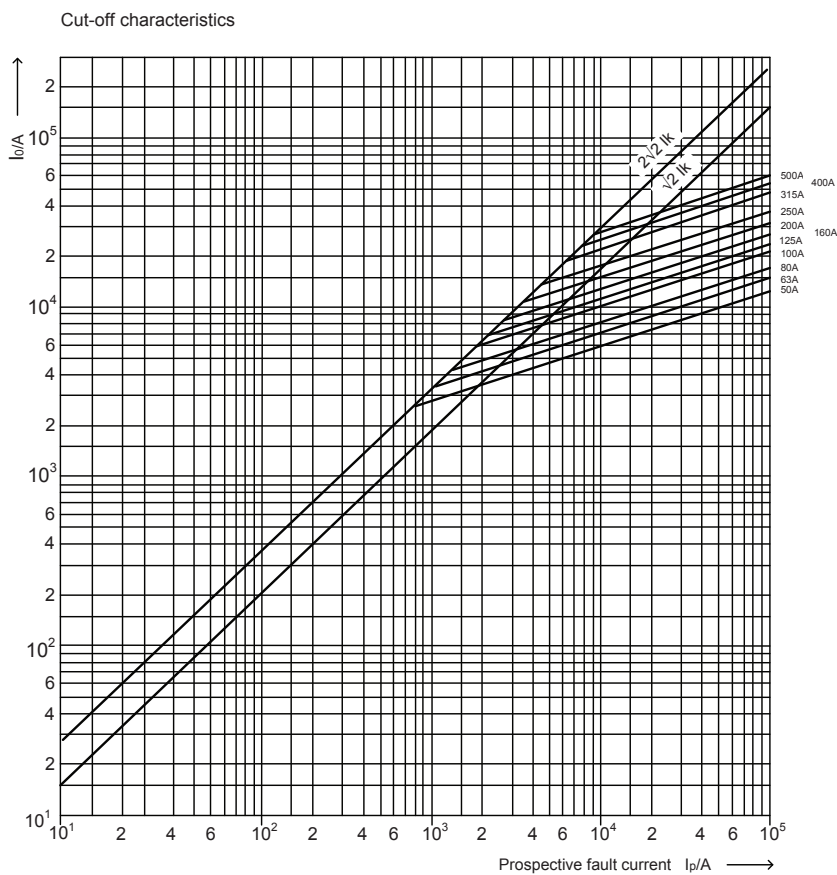
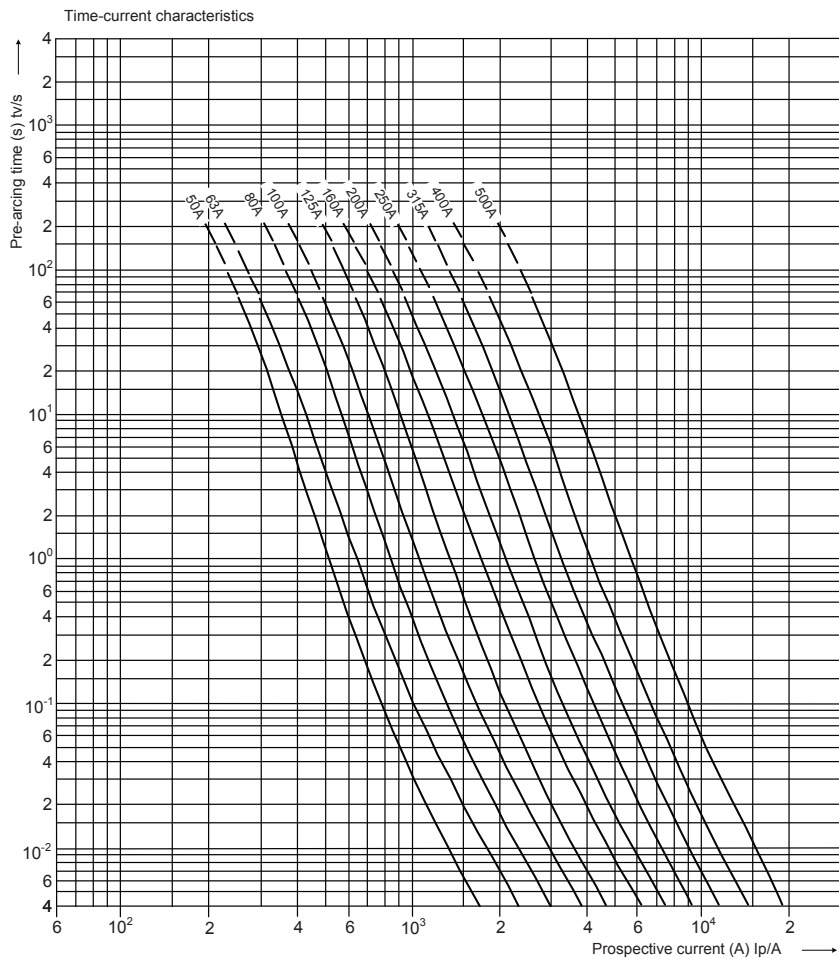

Fuse-link gB NV/NH 00 1000V a.c.

General characteristics	
Rated voltage	1000V a.c.
Breaking capacity	25kA a.c.
Standards	VDE 0636-2011
Characteristic	gB
Application	For equipment protection in mining industry.

NV/NH gB 1000V a.c.								
Size	I _n [A]	Standard indicator	Pre-arcing Joule integral [A ² s]	Operating Joule integral [A ² s] at 635V	Operating Joule integral [A ² s] at 1100V	Power dissipation [W]	Weight [g]	Packaging [pcs]
00	25	004182475	250	1000	1500	12	350	3/45
	32	004182476	400	1600	2300	13		
	35	004182477	700	2500	3800	14		
	40	004182478	800	3000	4200	15		
	50	004182479	1200	4500	7000	16		
	63	004182480	2000	8000	11000	19		
	80	004182481	3000	12000	17000	21		
	100	004182482	6000	25000	35000	24		
125	004182483	9000	30000	43000	27			

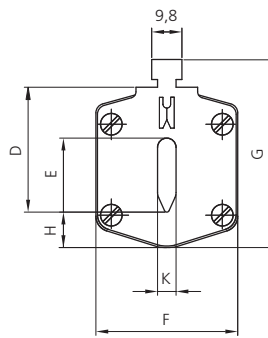
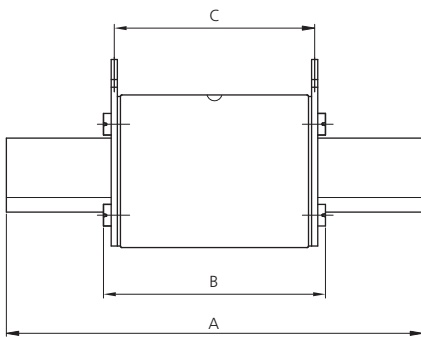

Size	Dimensions [mm]									
	A	B	C	D	E	F	G	H	K	
00	117	92	85	35	15	30	60	12	6	



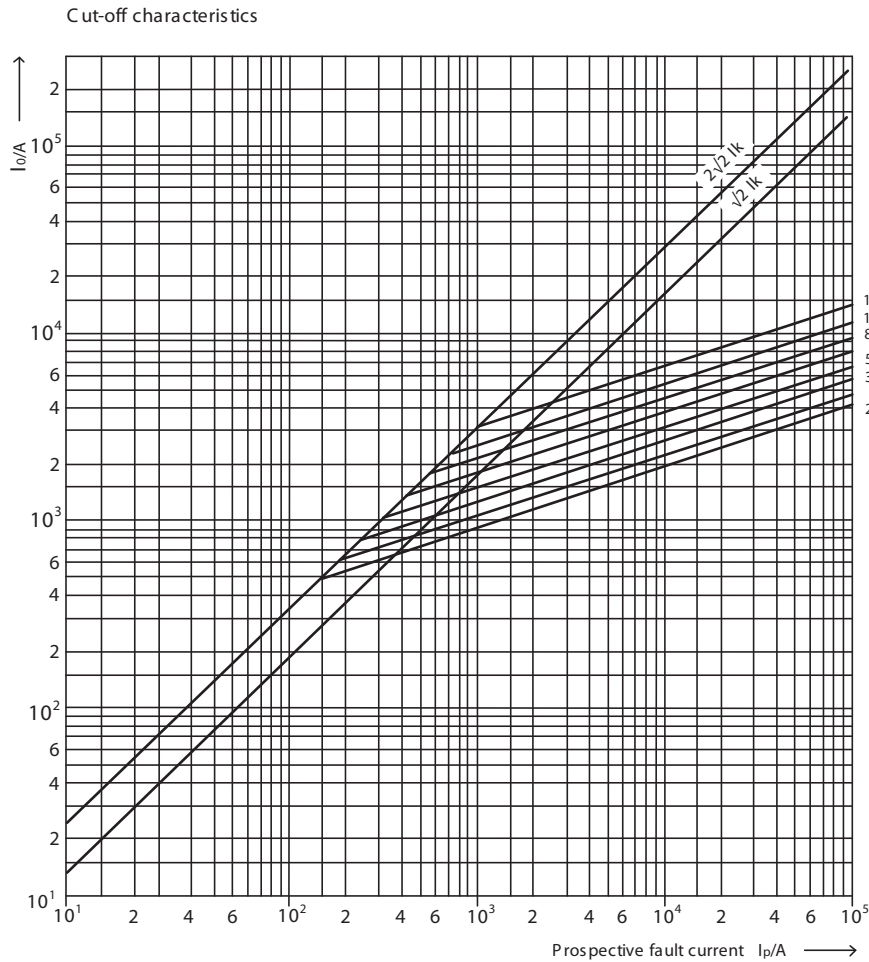
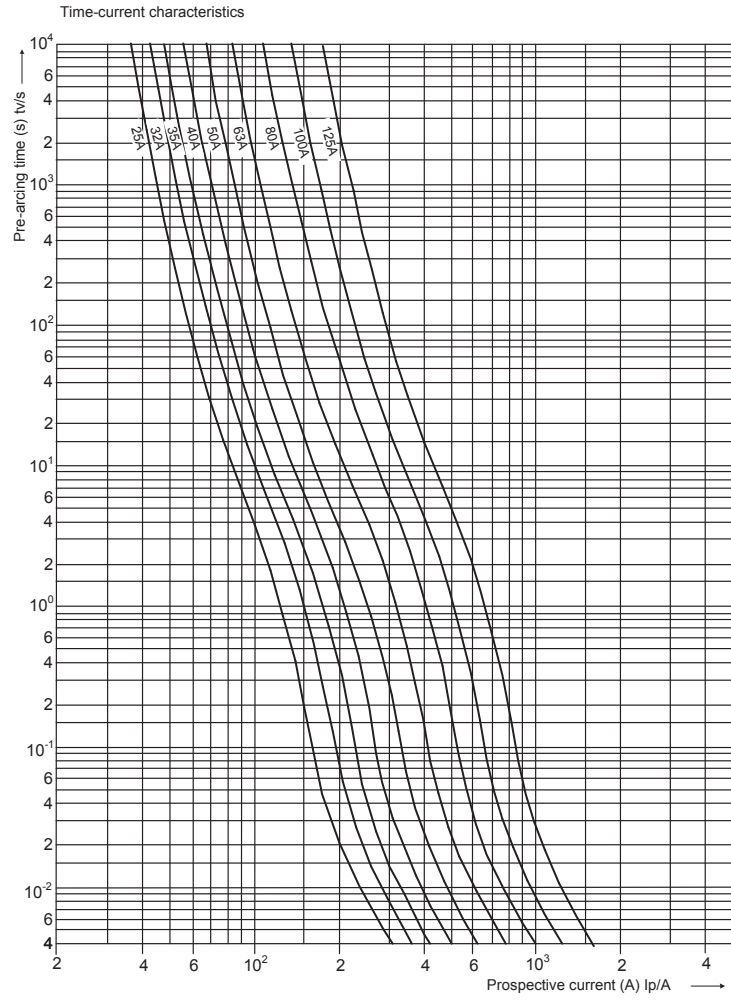

Fuse-link gG NV/NH 1200 V a.c.

General characteristics	
Rated voltage	1200V a.c.
Breaking capacity	50 kA a.c.
Standards	IEC 60269
Characteristic	gG

1200V a.c. gG						
Size	I _n [A]	Standard indicator (pic.1)	Striker indicator - K (pic.2)	Power dissipation [W]	Weight [g]	Packaging [pcs]
1XL	6	004113721	004113796	3,2	750	1
	10	004113722	004113797	3,7		
	16	004113723	004113798	4,1		
	20	004113724	004113799	5,0		
	25	004113725	004113800	5,0		
	32	004113726	004113801	5,8		
	35	004113727	004113802	6,1		
	40	004113728	004113803	8,1		
	50	004113729	004113804	8,8		
	63	004113730	004113805	10,2		
	80	004113731	004113806	11,0		
	100	004113732	004113807	12,0		
	125	004113733	004113808	16,0		
	160	004113734	004113809	19,0		
200	004113735	004113810	25,0			
2XL	32	004113736	004113811	5,8	1050	1
	35	004113737	004113812	6,1		
	40	004113738	004113813	8,1		
	50	004113739	004113814	8,8		
	63	004113740	004113815	10,2		
	80	004113741	004113816	11,0		
	100	004113742	004113817	12,0		
	125	004113743	004113818	16,0		
	160	004113744	004113819	19,0		
	200	004113745	004113820	25,0		
250	004113746	004113821	30,0			
315	004113747	004113822	35,0			
3L	80	004113748	004113823	11,0	1360	1
	100	004113749	004113824	12,0		
	125	004113750	004113825	16,0		
	160	004113751	004113826	19,0		
	200	004113752	004113827	25,0		
	250	004113791	004113828	30,0		
	315	004113792	004113829	35,0		
	355	004113790	-	37,0		
	400	004113793	004113830	40,0		
	500	004113794	004113831	50,0		
630	004113795	004113832	70,0			



Picture 1

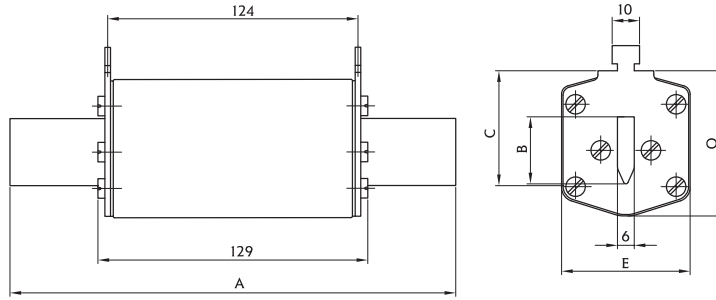

Picture 2

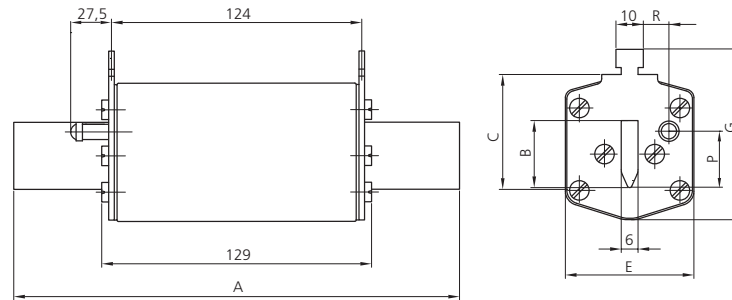

Size	Dimensions [mm]								
	A	B	C	E	G	P	R	M	O
1XL	194	24	40	46	61,5	20,5	13,7	50	52
2XL	209	30	48	54	71	27,3	16,2	59	61
3L	209	37	60	64	82	35,6	17,0	70	74

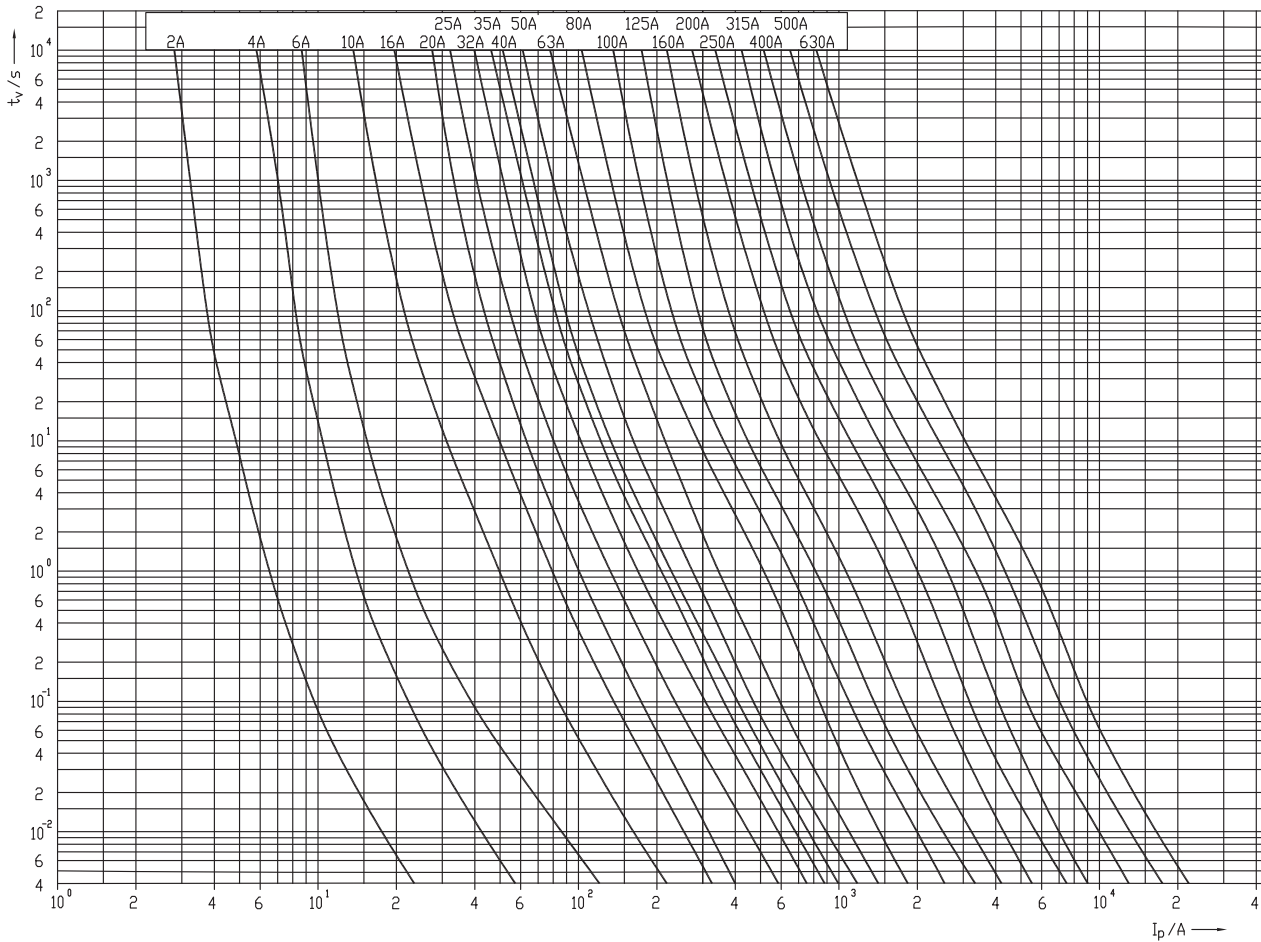

NV 1200V a.c. gG I/t characteristics

Safe work fuses

Fuse links SWF

ETI offer fuse links type SWF for protection against arc.

Characteristics of SWF fuse links:

- current limiting
- short operating time
- available in size 000,1,2,3 acc. standard DIN 43620
- marking like "SWF fuse link"
- standard with top indicator

By replacing NH fuse link with a characteristic gG acc. to VDE 0636-21 with faster fuse link type SWF acc. to VDE 0636-23, we can safeguard persons against electrical arc.

Because of higher power dissipation, we can use SWF fuse link only between maintenance under voltage. After that, we must replace it with a gG fuse link.

Damaged SWF fuse links must necessarily be replaced with new SWF fuse links.



Arc energy

$$E_T \propto I_{RMS}^2 \times t$$

E_T (protection with SWF fuse link)	E_T (protection with gG fuse link)
1	∞ 30

Selection nominal current of SWF fuse link:

$$I_n \text{ (SWF)} = I_n \text{ (gG)}$$



SWF fuse links					
Size	I [A]	Type	Code Nr.	Packaging [pcs]	Weight [g]
00 C	32	M00C/SWF/32A/500V	004711220	3	130
	35	M00C/SWF/35A/500V	004711221		
	40	M00C/SWF/40A/500V	004711222		
	50	M00C/SWF/50A/500V	004711223		
	63	M00C/SWF/63A/500V	004711224		
	80	M00C/SWF/80A/500V	004711225		
	100	M00C/SWF/100A/500V	004711226		
	125	M00C/SWF/125A/500V	004711227		
	160	M00C/SWF/160A/500V	004711228		
1	63	M1/SWF/63A/500V	004713220	3	420
	80	M1/SWF/80A/500V	004713221		
	100	M1/SWF/100A/500V	004713222		
	125	M1/SWF/125A/500V	004713223		
	160	M1/SWF/160A/500V	004713224		
	200	M1/SWF/200A/500V	004713225		
	224	M1/SWF/224A/500V	004713226		
	250	M1/SWF/250A/500V	004713227		
2	125	M2/SWF/125A/500V	004714225	3	660
	160	M2/SWF/160A/500V	004714226		
	200	M2/SWF/200A/500V	004714227		
	224	M2/SWF/224A/500V	004714228		
	250	M2/SWF/250A/500V	004714229		
	315	M2/SWF/315A/500V	004714230		
	350	M2/SWF/350A/500V	004714231		
	400	M2/SWF/400A/500V	004714232		
3	250	M3/SWF/250A/500V	004715230	3	870
	315	M3/SWF/315A/500V	004715231		
	350	M3/SWF/350A/500V	004715232		
	400	M3/SWF/400A/500V	004715233		
	425	M3/SWF/425A/500V	004715234		
	500	M3/SWF/500A/500V	004715235		

Fuses for TVSS products protection

SRF Series Surge Fuse

Through the past few years, the transient voltage surge suppression (TVSS) industry has grown to one of the fastest-growing segments among power protection products. Newness from ETI is series of fuses named SRF (Surge Rated Fuses), intended for the protection of TVSS products. The SRF Series has been designed to survive 8/20 μ s or 10/350 μ s lighting surge pulses without operating, allowing the TVSS system to react to the surge. Surge fuses have either 8/20 μ s or 10/350 μ s ratings, not a continuous current rating.

These fuses are intended to be installed in series with the TVSS devices and do not normally carry current, except for the periodic random surges caused by TVSS breakdown during normal operation. Under AC short circuit conditions these SRF surge suppression fuses have extremely high capability for current limitation.

Features / Benefits

- Rated voltage 600V a.c. (8/20 μ s) or 400V a.c. (10/350 μ s)
- Breaking capacity 200 kA (8/20 μ s) or 50kA (10/350 μ s)
- Available in Surge Ratings from 10 kA to 40 kA (8/20 μ s) and 25 kA (10/350 μ s)
- Designed to meet UL1449 Second Edition requirements,
- Comply with the applicable requirements in UL 248-1 Low Voltage Fuses – Part 1, General Requirements.

Approvals

Recognized under the components program of Underwriters Laboratories for Special Purpose Fuses, File number UL E310767 (SRF 10).

CH SRF class II

General characteristics	
Designed for	8/20 lighting surge pulses
Rated voltage	600V a.c.
Breaking capacity	200kA a.c.
Standards	Comply with the applicable requirements in UL 248-1 Low Voltage Fuses- Part1, General Requirements.
Application	These fuses are intended for installation in series with TVSS devices and do not normally carry current, except for the periodic random surges caused by TVSS breakdown during normal operation.



CH SRF 8/20 μ s								
Size	Type	Code No.	8x20 μ sec Surge rating [A]	Melting I ² t [A ² s]	Total I ² t [A ² s]	I _{PEAK} at 130 kA	Packaging [pcs]	Weight [g]
14x51	CH14 SRF10-II	002636004	10.000	2.360	10.370	8.320	10/500	18,6
	CH14 SRF20-II	002636005	20.000	5.490	17.700	10.430		
	CH14 SRF30-II	002636006	30.000	16.750	39.880	13.540		
	CH14 SRF40-II	002636007	40.000	33.680	72.800	17.480		
22x58	CH22 SRF60-II	002646006	60.000	133.630	247.180	21.260	10/480	55

CH SRF 25kA class I

General characteristics	
Designed for	10/350 lighting surge pulses
Rated voltage	400V a.c.
Breaking capacity	50kA a.c.
Standard	61463-11
Application	These fuses are intended for installation in series with TVSS devices and do not normally carry current, except for the periodic random surges caused by TVSS breakdown during normal operation.

CH 22x58 SRF 25kA 10/350 μ s							
Size	Type	Code Number	10/350 μ sec Surge rating [A]	Pre-arcing Joule integral [A ² s]	Operating Joule integral [A ² s]	Packaging [pcs]	Weight [g]
22x58	CH22 SRF25-I	002646010	25.000	322.700	504.300	24/240	55

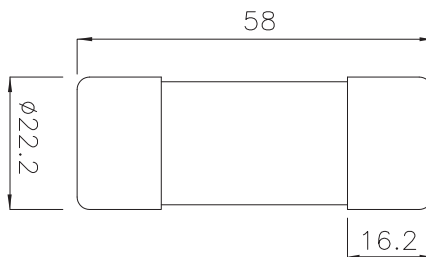

CH SRF class II - DC

General characteristics	
Designed for	8/20 μ sec lighting surge pulses
Rated voltage	1000V d.c.
Breaking capacity	1000A d.c.
Fuses withstand not only a single shot of surge current, but a sequence of min.15 shots of surge current.	
Application	Use in typical DC application: PV Photovoltaic, battery supply, rectifier These fuses are intended for installation in series with TVSS devices and do not normally carry current, except for the periodic random surges caused by TVSS breakdown during normal operation.

CH 22x58SRF DC 8/20 μ s							
Size	Type	Code Number	8/20 μ sec Surge rating [A]	Pre-arcing Joule integral [A ² s]	Operating Joule integral [A ² s]	Packaging [pcs]	Weight [g]
22x58	CH22 SRF3-II-DC	002646015	3.000	660	1380	10/480	55
	CH22 SRF8-II-DC	002646016	8.000	6.930	8.730		
	CH22 SRF12-II-DC	002646017	12.000	85.500	86.500		

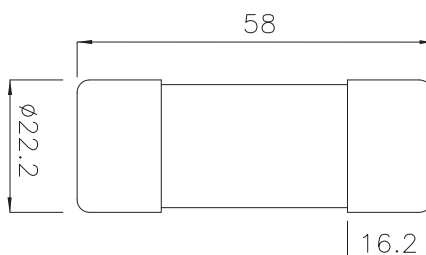

Fuses for railway applications

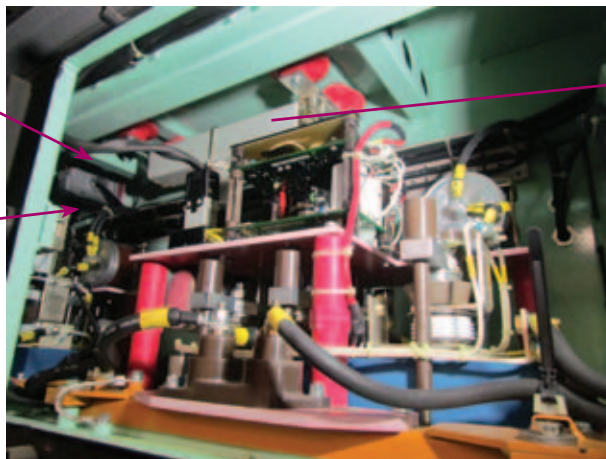

Advantages

ETI's Railway Fuses successfully combine two usually conflicting fuse requirements:

- ✓ **low operating joule integral**, necessary for the protection of semiconductors,
- ✓ **low power dissipation**, allowing for lower energy losses and thus **lower operating costs**, following the latest ecological trends.

These unique technical characteristics are achieved by a completely **new design of the ceramic body**, a special construction developed on the basis of long standing expert knowledge, which allows for significantly better cooling of the fuse.

The operation of fuses is especially **adapted for railway applications**, as they have **improved resistance to current cyclic loading**, a phenomenon that causes unnecessary fuse operating in these applications. This way, ETI's Railway Fuses help **decrease downtime** significantly, leading to further **cost savings** and **improved efficiency**.

The melting element inside Railway Fuses is made of silver, which makes them **highly insensitive to ageing** processes.

ETI Railway fuse-links ensure short circuit protection from minimum breaking capacity ($5 \times I_n$) up to maximum breaking capacity 30kA d.c. at time constant 15ms.

Application

Protection of DC link and semiconductor devices (diodes, thyristors, GTO) in railway inverters.

Standards

ETI Railway Fuses comply with the IEC 60269-4 and IEC 60077-5 standards.

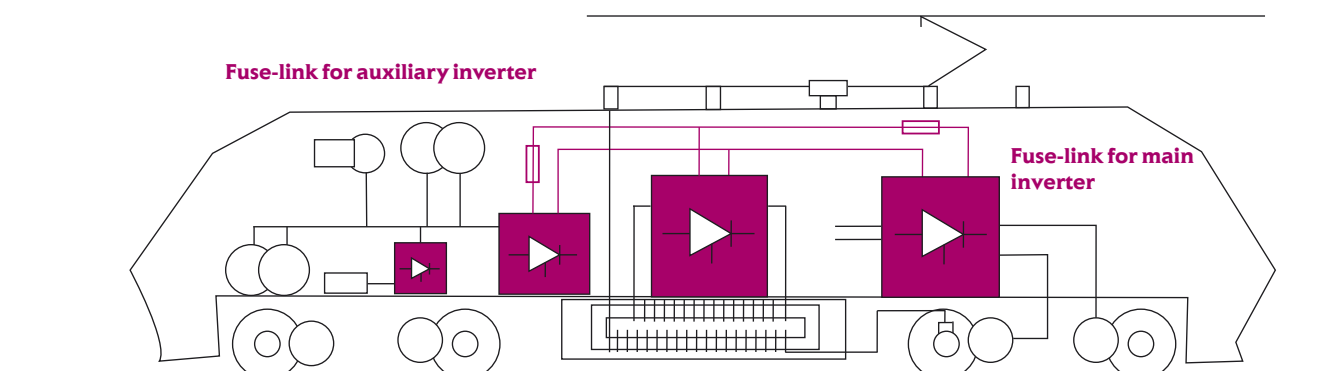

NH1S/394/DC 4000V aR-fuse link

General characteristics	
Rated voltage	4000V d.c. (L/R=15ms), rated test voltage 4200V d.c.
Breaking capacity	30kA d.c.
Characteristic	aR
Standards	IEC 60269-4, IEC 60077-5
Application	Heating system in railway vagon

RAILWAY fuse link							
I_n [A]	Code No. Type with centre trip indicator for microswitch MK	Code No. Type without centre trip indicator for microswitch MK	Power dissipation [W]	Pre-arcing Joule integral [A ² s]	Operating Joule integral [A ² s] (L/R=15ms)	Weight [g]	Pack. [pcs]
25	004735615	004735627	43	28	150	1800	1/1
32	004735616	004735628	65	40	300		
40	004735617	004735629	88	63	600		
50	004735618	004735630	105	112	1.400		
63	004735619	004735631	105	252	2.500		
80	004735620	004735632	114	494	5.500		
100	004735621	004735633	115	1.147	10.000		
125	004735622	004735634	132	2.168	19.000		
150	004735623	004735635	155	3.388	31.000		

Note: microswitch MK and adapter AMK1 must be ordered separately

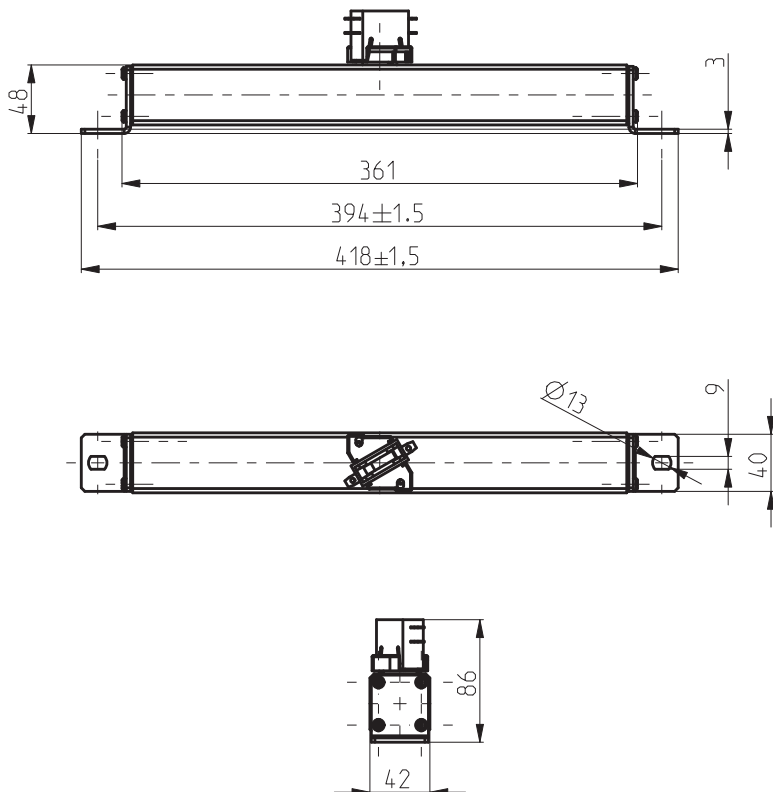

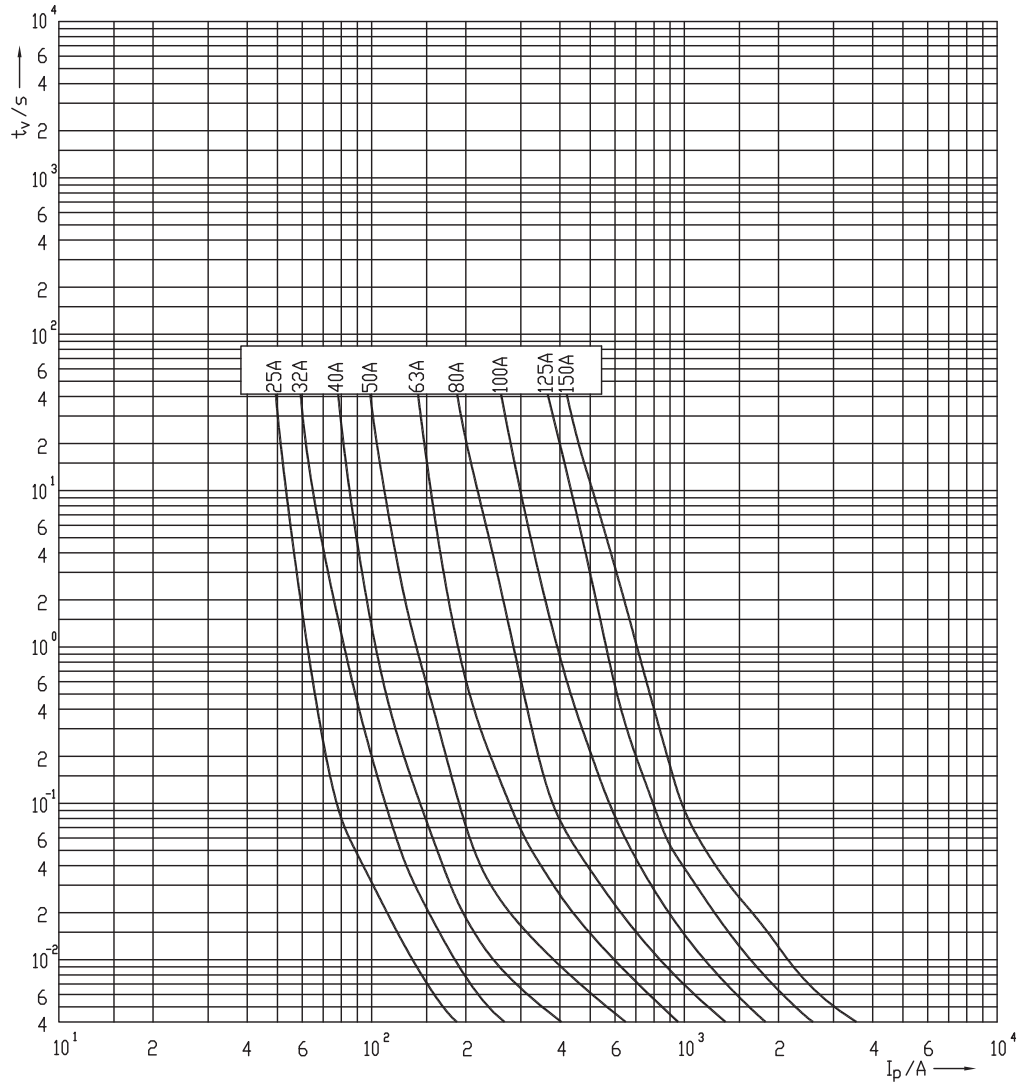

NH2 S/394/ DC 4000V aR - fuse link

General characteristics	
Rated voltage	4000V d.c. (L/R=15ms), rated test voltage 4200V d.c.
Breaking capacity	30kA d.c.
Characteristic	aR
Standards	IEC 60269-4, IEC 60077-5
Application	Fuse link for DC link protection of railway inverter.

RAILWAY fuse link							
I_n [A]	Code No. Type with centre trip indicator for microswitch MK	Code No. Type without centre trip indicator for microswitch MK	Power dissipation [W]	Pre-arcing Joule integral [A ² s]	Operating Joule integral [A ² s] (L/R=15ms)	Weight [g]	Pack. [pcs]
100	004735601	004735606	58	2.300	20.000	3500	1/1
125	004735602	004735607	82	3.700	33.000		
160	004735603	004735608	100	5.800	55.000		
200	004735604	004735609	127	10.000	100.000		
250	004735605	004735610	160	21.000	180.000		

Note: microswitch MK and adapter AMK2 must be ordered separately

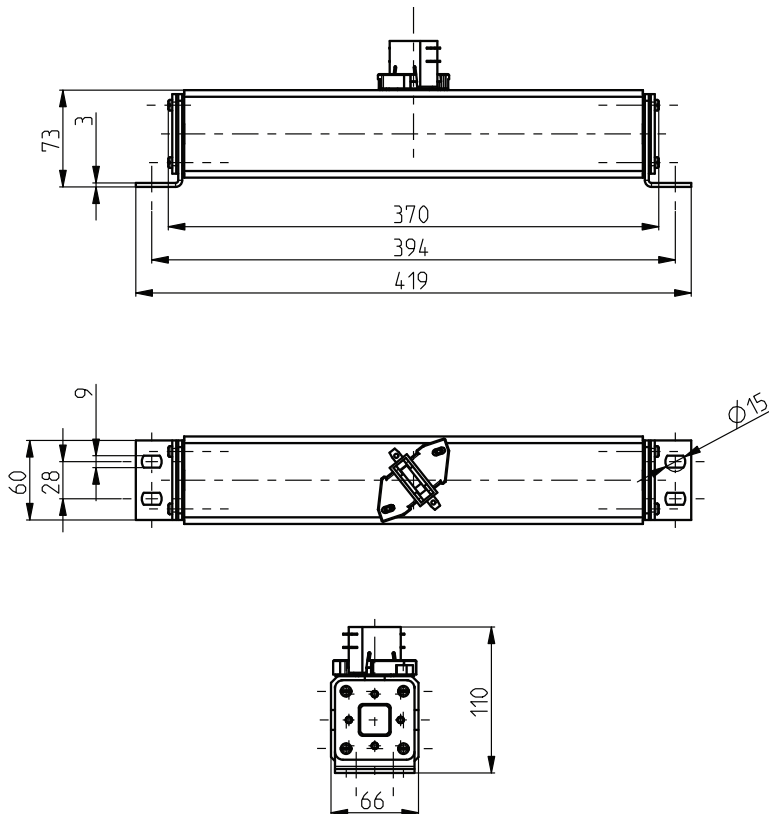

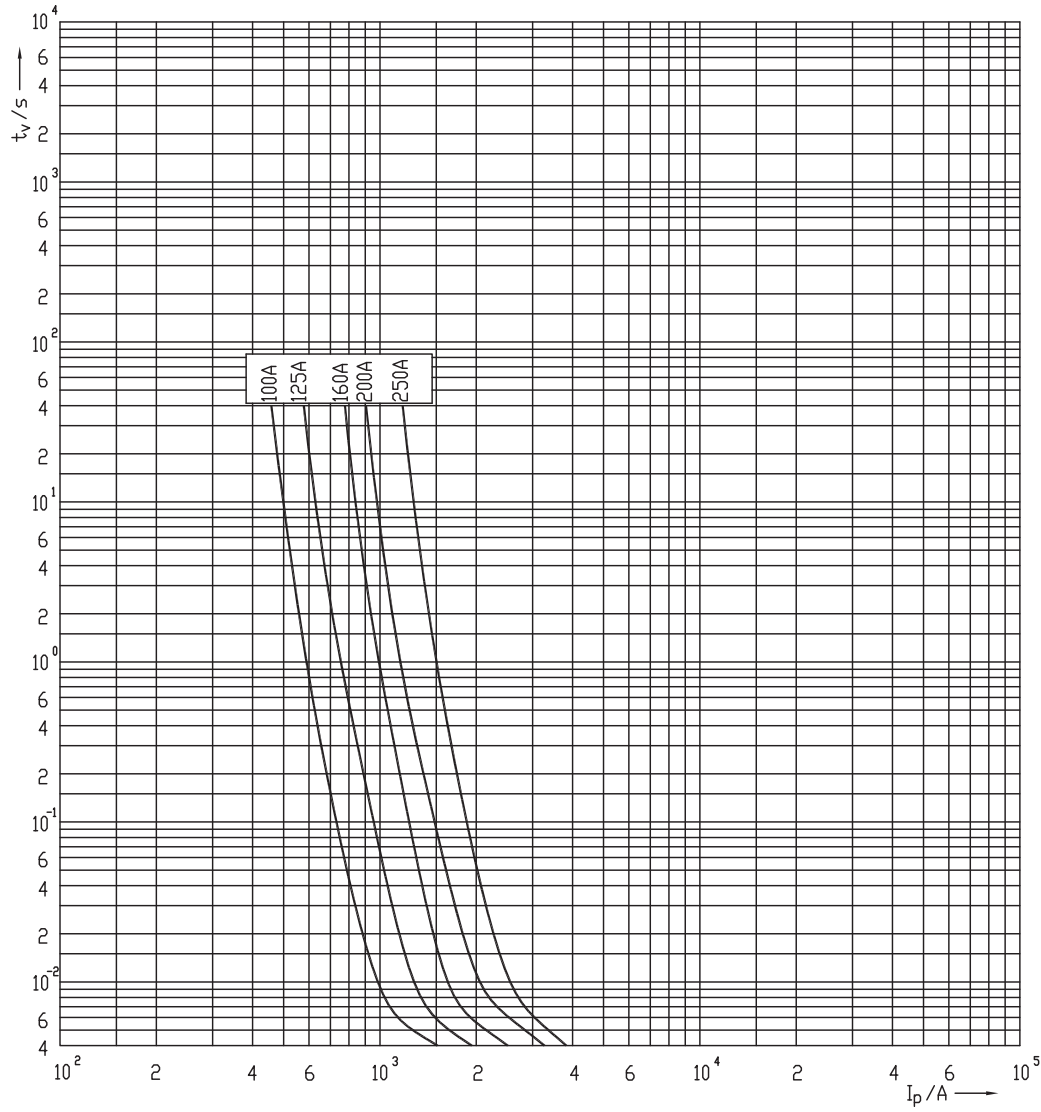

NH1 /350/DC 4000V aR-fuse link

General characteristics	
Rated voltage	4000V d.c. (L/R=15ms)
Breaking capacity	30kA d.c.
Characteristics	aR
Standard	IEC 60269-4, IEC 60077-5
Application	Heating system in railway vagon

RAILWAY fuse link						
I_n [A]	Code No.	Power dissipation [W]	Pre-arcing Joule integral [A ² s]	Operating Joule integral [A ² s] (L/R=15ms)	Weight [g]	Pack. [pcs]
25	004735636	43	28	150	1800	1/1
32	004735637	65	40	300		
40	004735638	88	63	600		
50	004735639	105	112	1.400		
63	004735640	105	252	2.500		
80	004735641	114	494	5.500		
100	004735642	115	1.147	10.000		
125	004735643	132	2.168	19.000		
150	004735644	155	3.388	31.000		

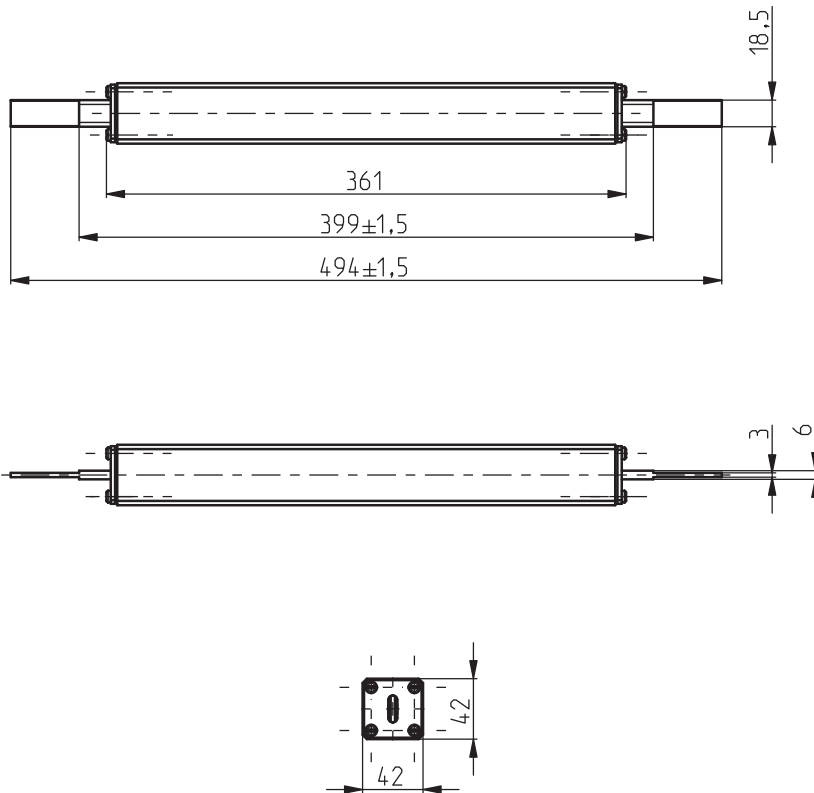

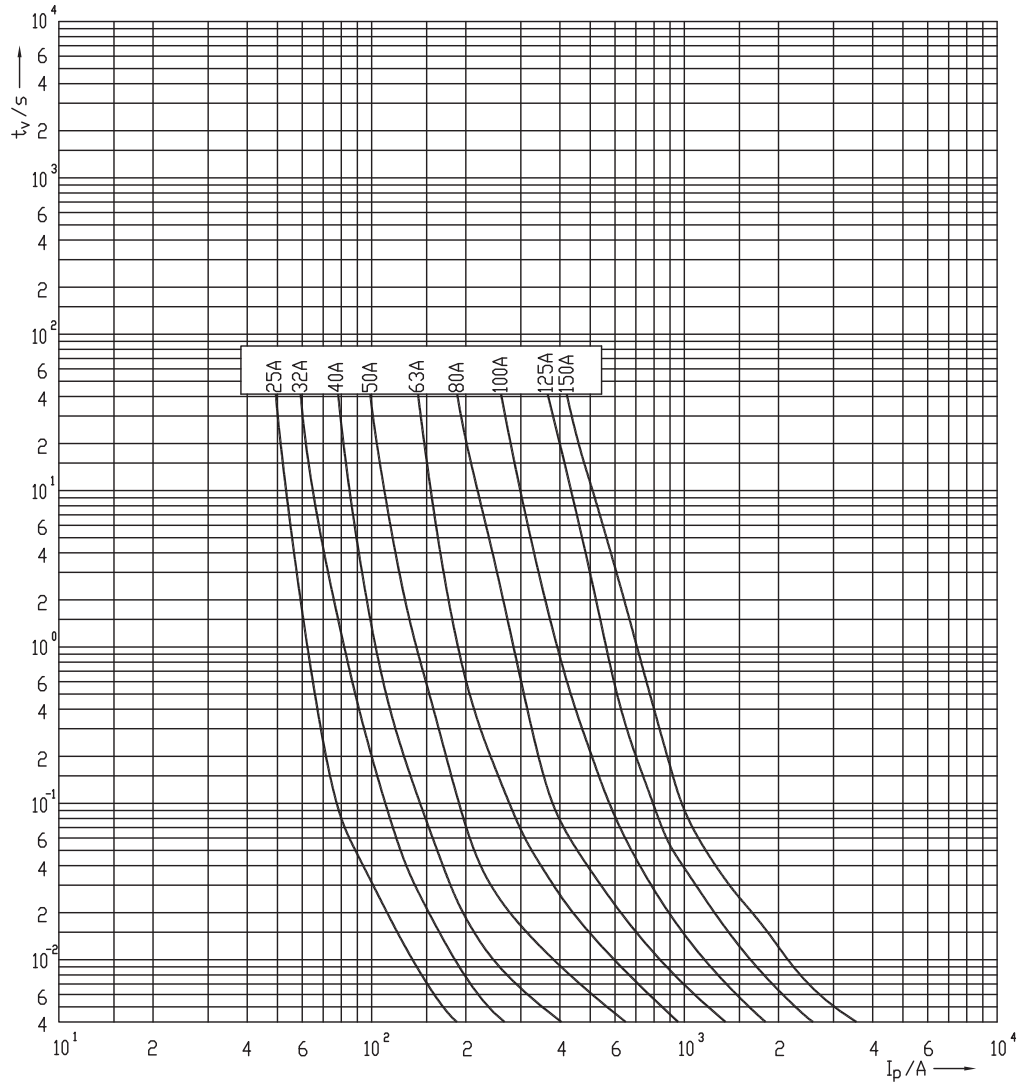

NH1 / 130 / DC 1000V gR - fuse link

General characteristics	
Rated voltage	1000V d.c. (L/R=10ms)
Breaking capacity	30kA d.c.
Characteristic	gR
Standards	IEC 60269-4
Application	Railway inverter protection

RAILWAY fuse link								
I_n [A]	Code No.	Code No. Type with centre trip indicator for microswitch MK+AMK2	Power dissipation [W]		Pre-arcing Joule integral [A ² s]	Operating Joule integral [A ² s] (L/R=15ms)	Weight [g]	Pack. [pcs]
160	004303530	004303527	15,3	36,5	10.000	16.000	900	1/16
200	004303531	004303528	17,5	42,6	18.000	38.000		
250	004303532	004303529	23,6	56	30.000	60.000		

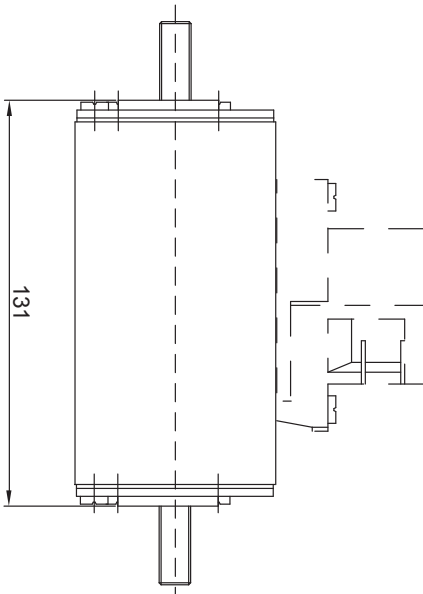
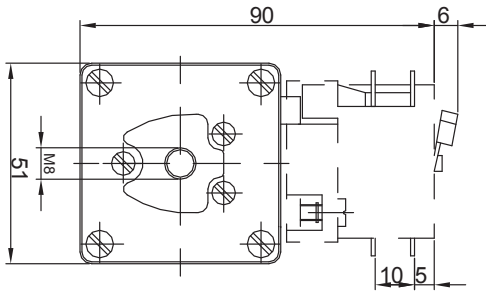

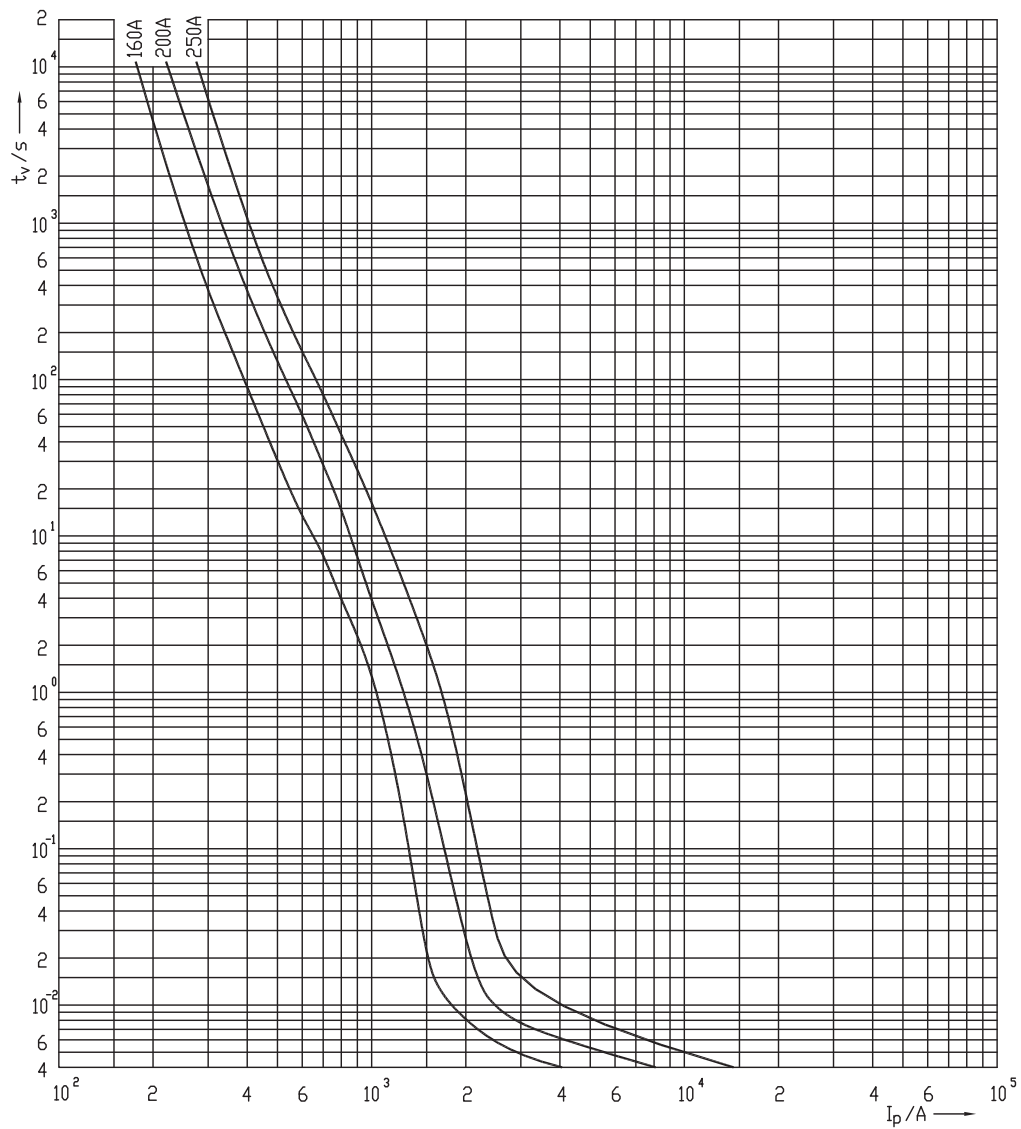

Fuses for high-voltage switchgear

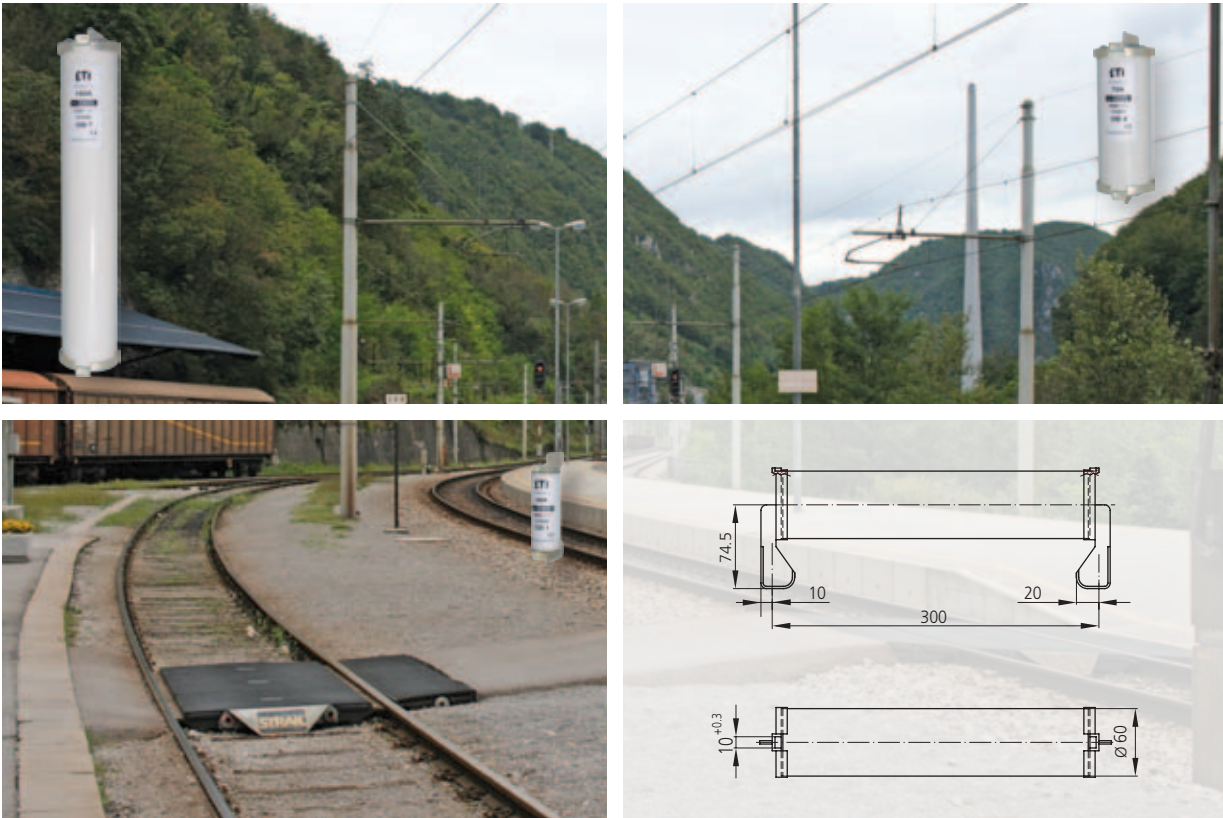

Fuses for high-voltage switchgear DB, S₃₆₈ Series

For the protection of high-voltage switchgear ETI offers a complete range of high-voltage fuses. The series-connected fuses provide failsafe surge protection for the downstream equipment in every situation. This is true for short circuits and also for overcurrents exceeding five times the value of the nominal current ($5 \times I_n$).

DB, S₃₆₈ series fuses are main fuses designed for nominal currents of 7,5 A to 125 A.

DB, S₃₆₈ series fuses are available for the following voltage ratings:

- 1 kV AC and 1 kV DC
- 1,5 kV AC and 1,5 kV DC
- 3 kV AC and 3 kV DC
- 5 kV DC

This range of fuses covers all existing train line voltages of the European railway systems.

Features

- Compact design
- 4 different sizes
- Fuses designed for 5 kV DC
- Standards: UIC 550, EN 50163 and IEC 60077-5.

Applications

- Main fuses for power supplies of rail vehicles, e.g. electric equipment and heating system
- Distribution fuses for branch circuits

Size	U_n [V]	I_n [A]	Code No.	Packaging [pcs]	Weight [g]
DB 1	1000	7,5	004735555	4	270
		10	004735556		
		16	004735557		
		20	004735558		
		25	004735559		
		30	004735560		
		40	004735562		



Size	U_n [V]	I_n [A]	Code No.	Packaging [pcs]	Weight [g]
DB 2	1000	50	004735564	4	450



Size	U_n [V]	I_n [A]	Code No.	Packaging [pcs]	Weight [g]
DB 3	1000	60	004735566	2	690
	1500	7,5	004735567		
		20	004735568		



Size	U_n [V]	I_n [A]	Code No.	Packaging [pcs]	Weight [g]
DB 4	1000	70	004735571	2	1000



Size	U_n [V]	I_n [A]	Code No.	Packaging [pcs]	Weight [g]
DB 5	1500	40	004735573	2	994
		60	004735575		
		10	004735576		
	3000	15	004735577		
		20	004735578		
		30	004735580		
		50	004735581		



Size	U_n [V]	I_n [A]	Code No.	Packaging [pcs]	Weight [g]
DB 6	1000	100	004735583	2	2050
		125	004735584		
		10	004735585		
	3000	20	004735586		
		30	004735587		
		40	004735588		
		50	004735589		
		60	004735590		
		70	004735591		



Size	U _n [V]	I _n [A]	Code No.	Packaging [pcs]	Weight [g]
DB 7	3000	100	004735593	1	2250

Size	U _n [V]	I _n [A]	Code No.	Packaging [pcs]	Weight [g]
S ₃₆₈	5000	20	004735594	1	3000
		30	004735595		
		40	004735596		
		50	004735597		
		60	004735598		
		70	004735599		
		100	004735600		



Size 1, 2, 3 and 5: Main fuses DB 1/2/3/5

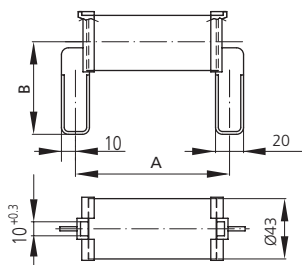

Size 8: Main fuses S₃₆₈

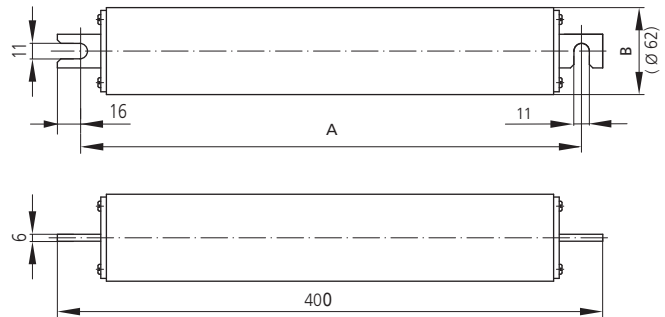

Size 4, 6 and 7: Main fuses DB 4/6/7

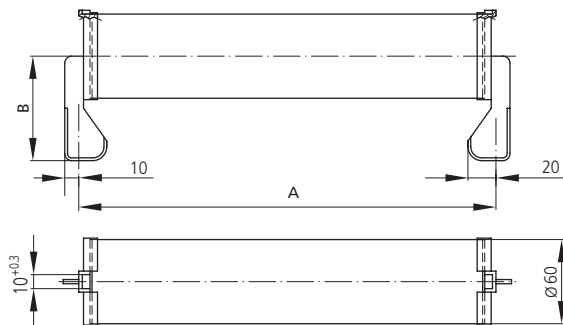

size	dimensions [mm]	
	A	B
DB 1	110	61,0
DB 2	110	61,0
DB 3	170	66,0
DB 4	170	74,5
DB 5	260	66,0
DB 6	300	74,5
DB 7	350	74,5
S ₃₆₈	368	62,0

Dimensions according to IEC 60269-2, see also ETI general catalogue

Cut-off characteristics SWF fuse links-size 00C,1,2,3

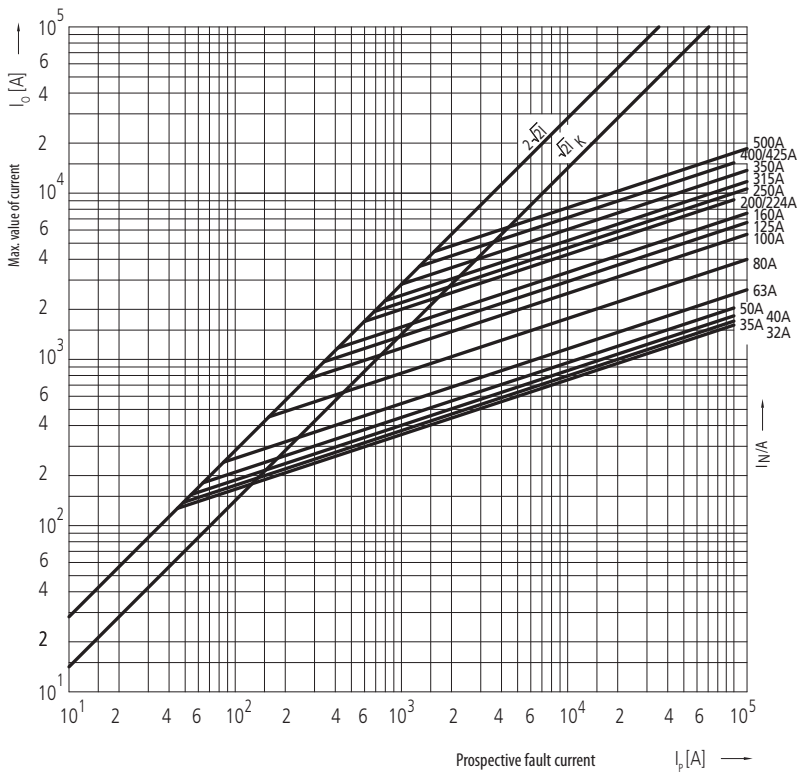

Time/current characteristics of fuse link type SWF-size 00C

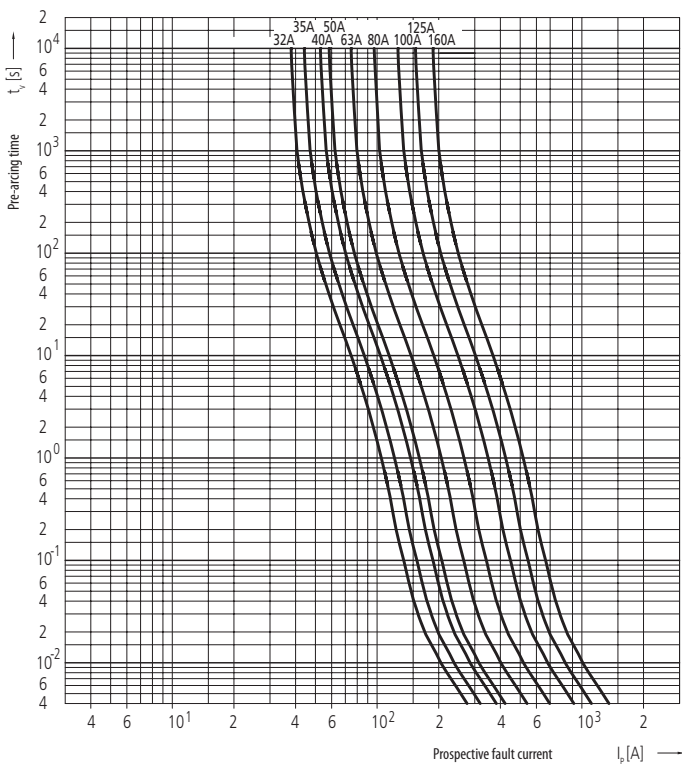

Time/current characteristics of fuse link type SWF-size 1,2,3

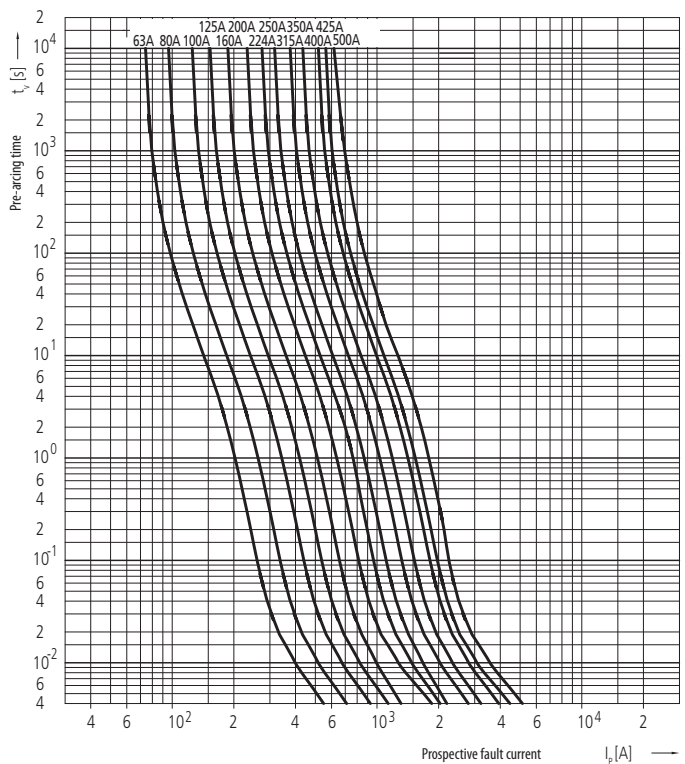

DB series 1.0 kV

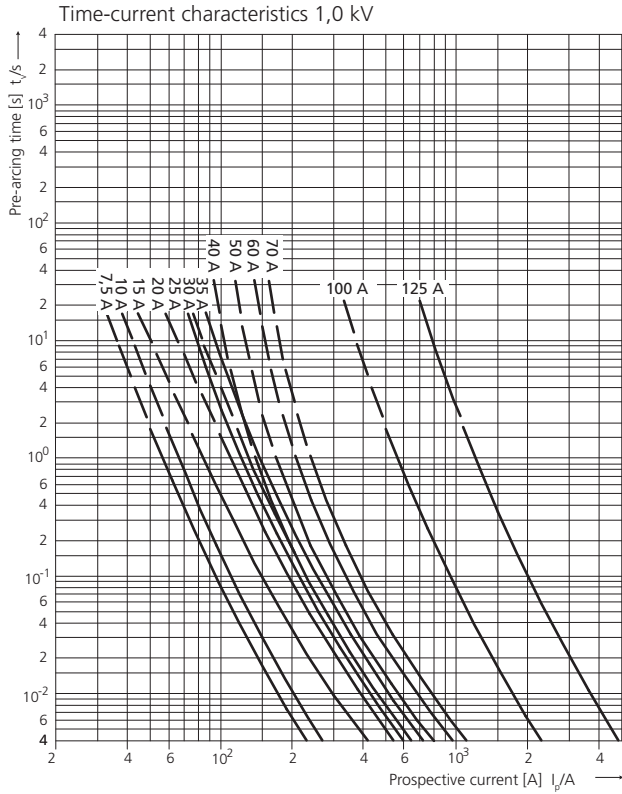

DB series 1.5 kV

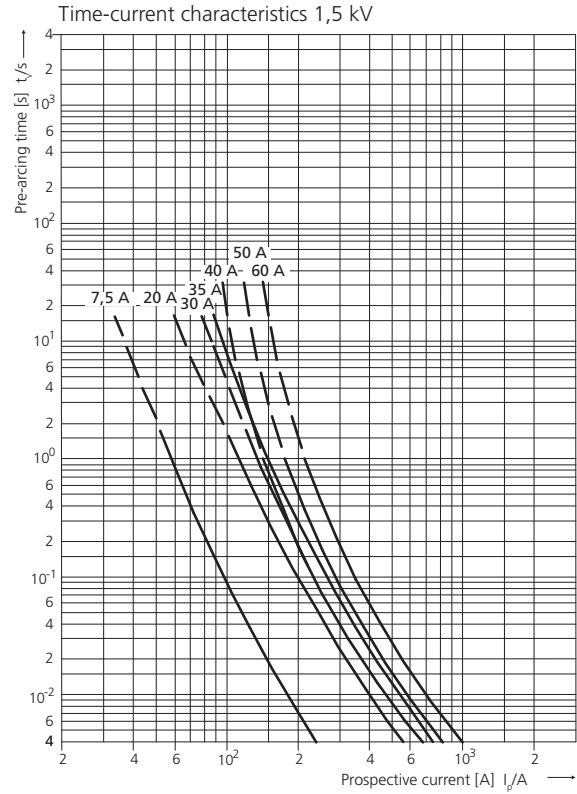

DB series 3.0 kV

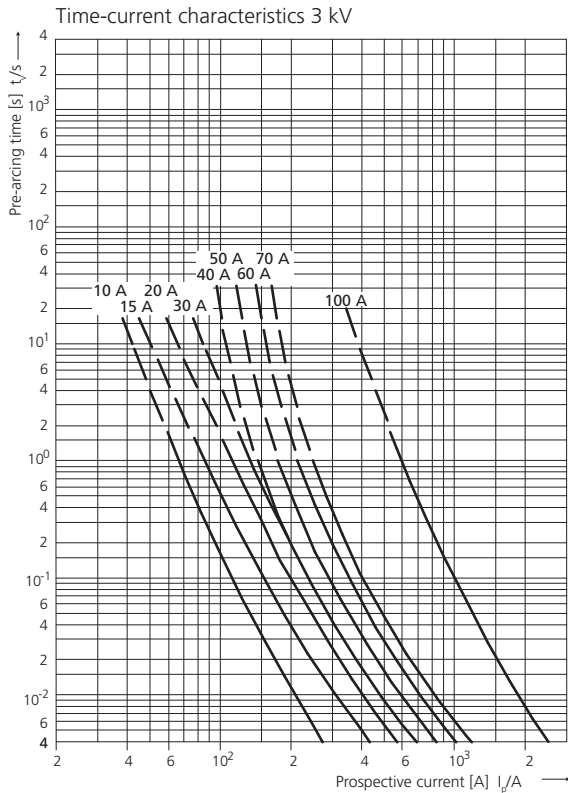

S₃₆₈ series 5 kV

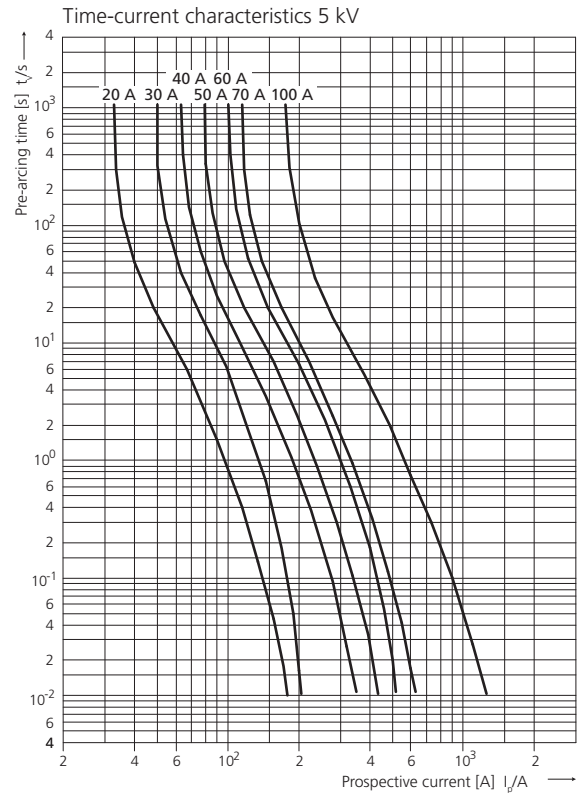

Battery Protection Fuses

Application

- in battery storage systems
- in UPS systems

Short circuit current

- Short circuit current depending on battery model, type and capacity, low compared to operating current
- Short circuit current has to be interrupted in <5 seconds

Required steep characteristics: protection with Battery fuse link required!

Operating current

- Operating current depends on battery storage specification
- Battery operation: voltage of DC link circuit decreases to the final discharge voltage

Consider maximum current at final discharge voltage for fuse link selection

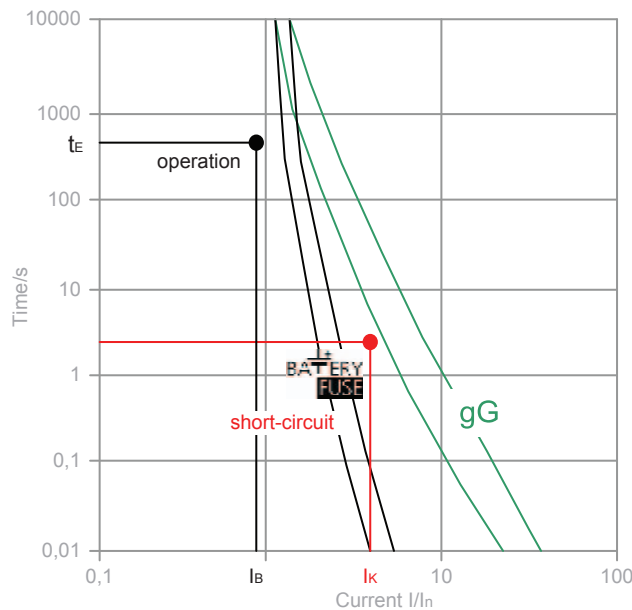

Short circuit point (I_k)

- Short circuit current depending on battery model and type
- Manufacturer datasheets to include short circuit current according to IEC896
- Operating point has to be in adequate distance below the curve
- Short-circuit point has to be above the range of tolerance of the curve

Operating point (t_E/I_B)

- maximum operating current I_B has to be calculated from battery storage true power and final discharge voltage U_E :

$$I_B = P_w / U_E$$
- t_E is the back-up time of battery storage system

When choosing fuse switch disconnector consider fuse link power dissipation!

$$P_d(I_B) < P_y$$

Power dissipation of fuse link at maximal operating current (I_B):

$$P_d(I_B) = (I_B / I_n)^2 \times P_d(I_n)$$

I_B - maximal operating current

$P_d(I_B)$ - power dissipation of fuse link at maximal operating current

$P_d(I_n)$ - power dissipation of fuse link at nominal current

P_y - maximal permissible fuse link power dissipation mounted in fuse switch disconnector

CH 10x38 BATTERY Fuse link 550V d.c.

General characteristics	
Rated voltage	550V d.c. (L/R=10ms)
Breaking capacity	30kA d.c.
Standard	IEC 60269
Application	Battery protection

CH BATTERY fuse link									
Size	I_n [A]	Code No. "standard contacts" 550V DC 30kA	Code No. "type SU contacts" 550V DC 30kA	Pre-arcing Joule integral L/R=10ms [A ² s]	Operat- ing Joule integral L/R=10ms [A ² s]	Power dissipation [0,7 x I_n] P_d [W]	Power dissipation [1 x I_n] P_d [W]	Weight [g]	Pack. [pcs]
10x38	2	002626002	002626102	1,1	1,8	0,47	1,12	10/12	10/500 SU: 10/380
	4	002626004	002626104	3,0	7,8	0,52	1,25		
	6	002626006	002626106	14,1	27,3	0,73	1,75		
	8	002626008	002626108	25,1	53,4	0,8	1,9		
	10	002626010	002626110	8,0	18,8	0,97	2,4		
	12	002626012	002626112	18,5	41,5	0,8	1,9		
	16	002626016	002626116	42	88	1,1	2,6		
	20	002626020	002626120	86	166	1,3	3,2		
25	002626025	002626125	140	270	1,65	4,1			



Note:
CH Battery fuse links are used in combination
with fuse disconnecter EFH 10 DC

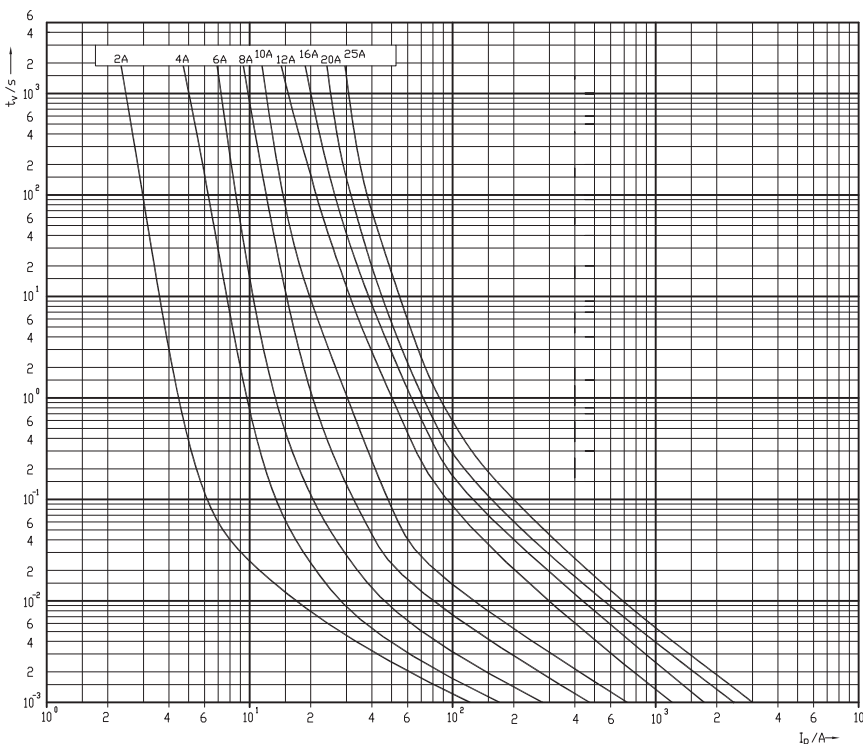

I/t characteristics for CH 10x38
Battery fuses

CH 10x38 BATTERY Fuse link 800V d.c.

General characteristics

Rated voltage	800V d.c. (L/R=10ms)
Breaking capacity	30kA d.c.
Standard	IEC 60269
Application	Battery protection

CH BATTERY fuse link

Size	I_n [A]	Code No. "standard contacts" 800V DC 30kA	Code No. "type SU contacts" 800V DC 30kA	Pre-arcing Joule integral L/R=10ms [A ² s]	Oper- ing Joule integral L/R=10ms [A ² s]	Power dissipation [0,7 x I_n] P_d [W]	Power dissipation [1x I_n] P_d [W]	Weight [g]	Pack. [pcs]
10x38	2	002626030	002626130	1,2	1,6	0,47	1,12	10/12	10/500 SU: 10/380
	4	002626032	002626132	3,6	8,9	0,52	1,25		
	6	002626034	002626134	9,5	27,2	0,73	1,75		
	8	002626036	002626136	27,3	65,8	0,8	1,9		
	10	002626038	002626138	8,2	26,6	0,97	2,4		
	12	002626040	002626140	20,6	54,6	0,8	1,9		
	16	002626042	002626142	44,4	109,3	1,1	2,6		



Note:
CH Battery fuse links
are used in combination
with fuse disconnecter
EFH 10 DC

Dimensions CH 10x38 Battery fuses

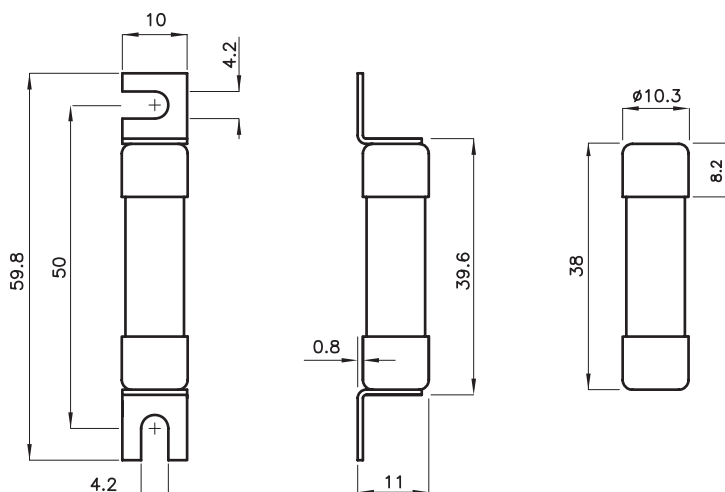

CH 14x51 BATTERY Fuse link 800V d.c.

General characteristics	
Rated voltage	800V d.c. (L/R=10ms)
Breaking capacity	30kA d.c.
Standard	IEC 60269
Application	Battery protection

CH BATTERY fuse link									
Size	I _n [A]	Code No. "standard contacts" 800V DC 30kA	Code No. "type SU contacts" 800V DC 30kA	Pre-arcing Joule integral L/R=10ms [A ² s]	Operat- ing Joule integral L/R=10ms [A ² s]	Power dissipation [0,7 x I _n] P _d [W]	Power dissipation [1 x I _n] P _d [W]	Weight [g]	Pack. [pcs]
14x51	16	002637405	002637505	37	136	1,4	3,1	19/21	10/200 SU: 10/260
	20	002637407	002637507	80	284	1,5	3,2		
	25	002637409	002637509	128	438	2	4		
	32	002637411	002637511	296	1050	2,1	5,1		
	36	002637412	002637512	370	1160	2,3	5,6		



Note:
CH Battery fuse links
are used in combination
with fuse disconnecter
EFH 14 DC.

Dimensions CH 14x51 Battery fuses

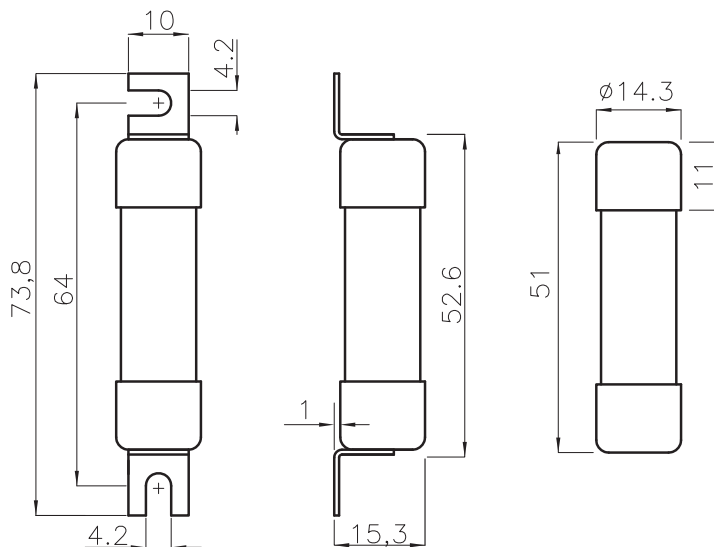

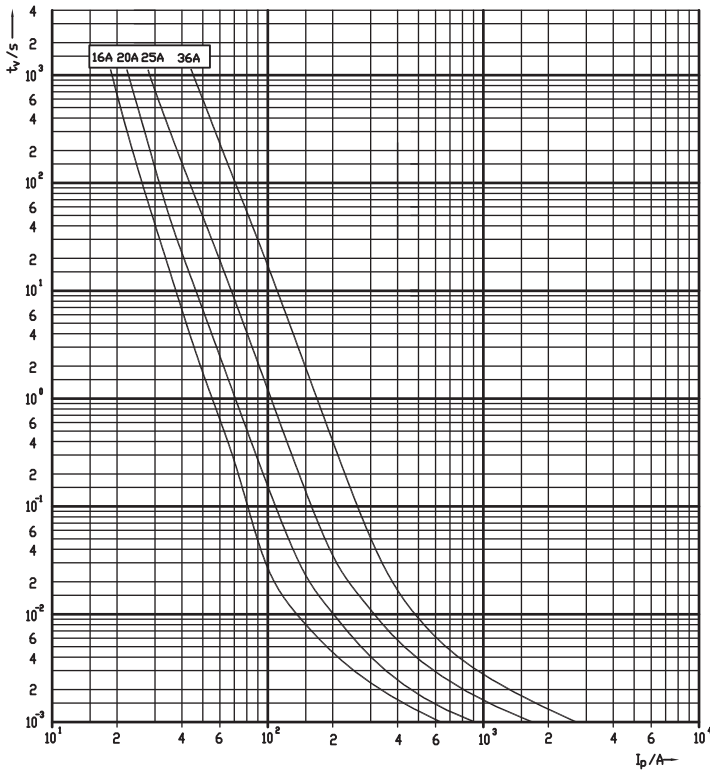

I/t characteristics for CH 14x51
Battery fuses

NH BATTERY fuse link 80V d.c.

Low power dissipation and fast characteristic in time range of 5s!

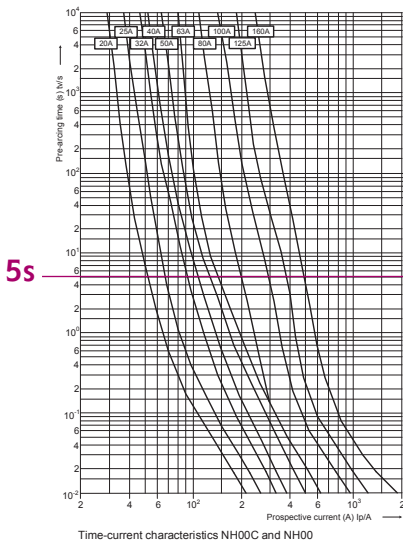

Discharge	-20~60°C
Charge	-10~60°C
Storage	-20~60°C
Max. Discharge Current 77°F(25°C)	1000A(5s)
Short Circuit Current	3300A
Charge Methods: Constant Voltage Charge 77°F(25°C)		
Cycle use	14.4-14.7V
Maximum charging current	60A
Temperature compensation	-30mV/°C

Better protection of battery cells on overheating in case of short circuit comparable to standard gG characteristic

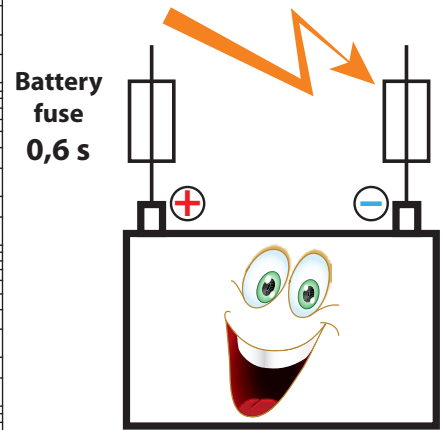
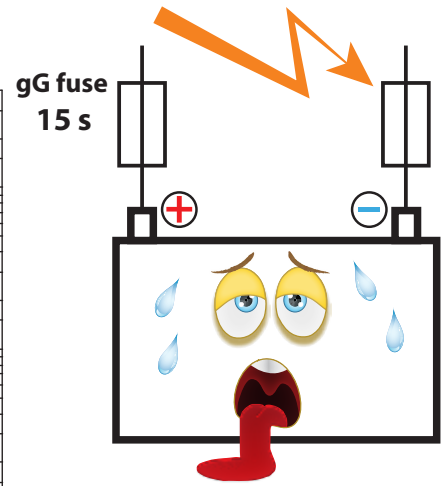
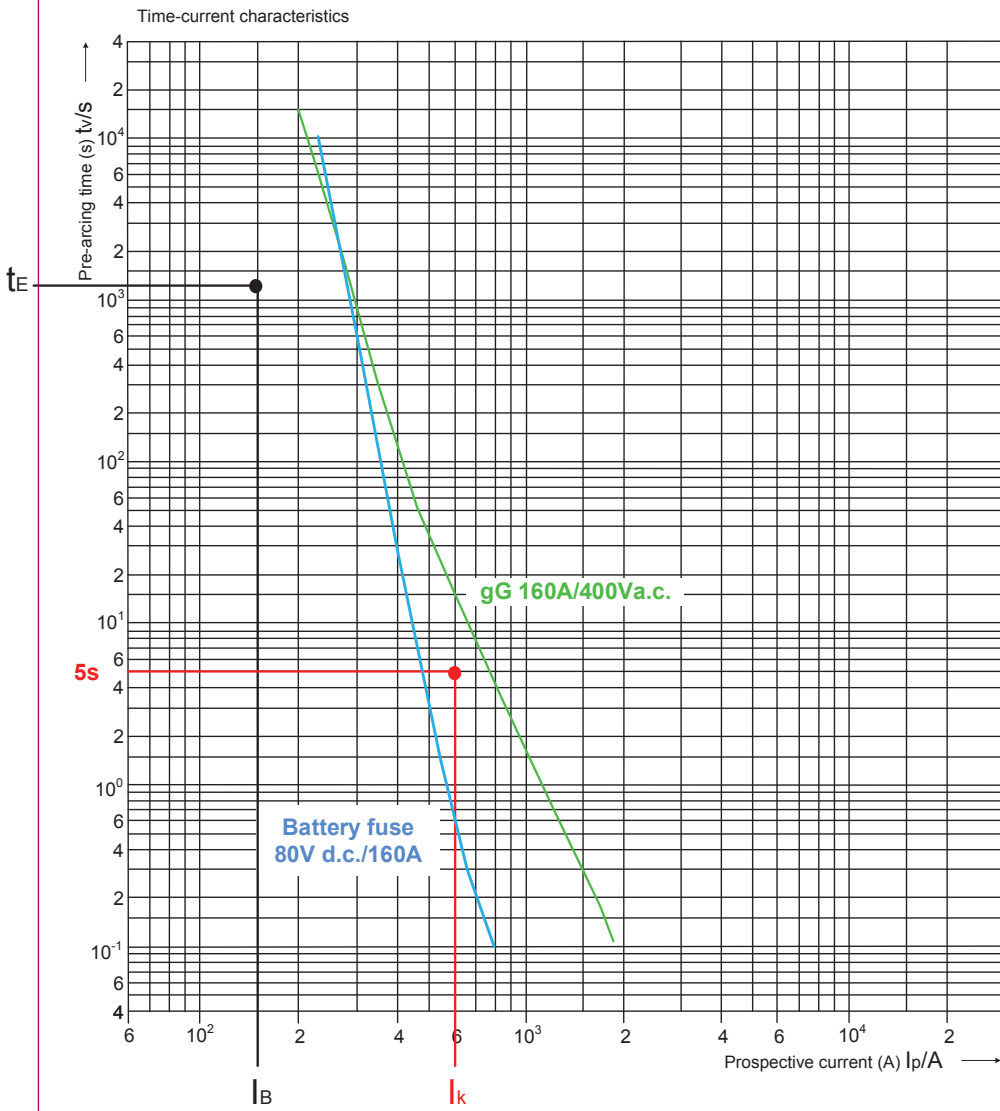

General characteristics

Rated voltage	80V d.c., L/R=10ms
Breaking capacity	50kA d.c..
Standard	IEC 60269
Application	Battery protection



NH BATTERY fuse link 80V d.c.					
Size	I_n [A]	Standard indicator Pic. 1	Power dissipation [W]	Weight [g]	Pack. [pcs]
00C	20	004110075	4,6	125	3/120
	25	004110076	5,8		
	32	004110077	6,6		
	40	004110078	9,4		
	50	004110079	11,1		
00	63	004110080	11,7	173	3/90
	80	004110081	10,4		
	100	004110082	11,1		
	125	004110083	13,4		
	160	004110084	15,5		
	200	004110085	17,6		
1C	20	004110085	6,3	233	3/45
	25	004110086	7,3		
	32	004110087	9		
	40	004110088	11,2		
	50	004110089	14,5		
	63	004110090	16,8		
	80	004110091	11,4		
	100	004110092	12		
	125	004110093	14,8		
	160	004110094	17,6		
1	200	004110095	26,6	430	3/24
	250	004110096	31		



I/t characteristics for NH Battery fuses 80V d.c.

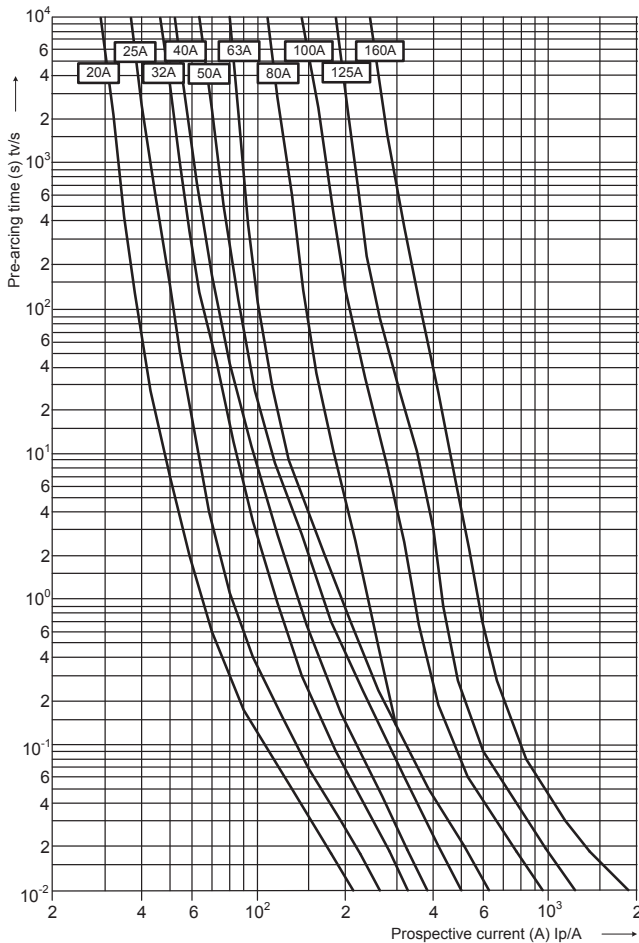

Time-current characteristics NH00C and NH00

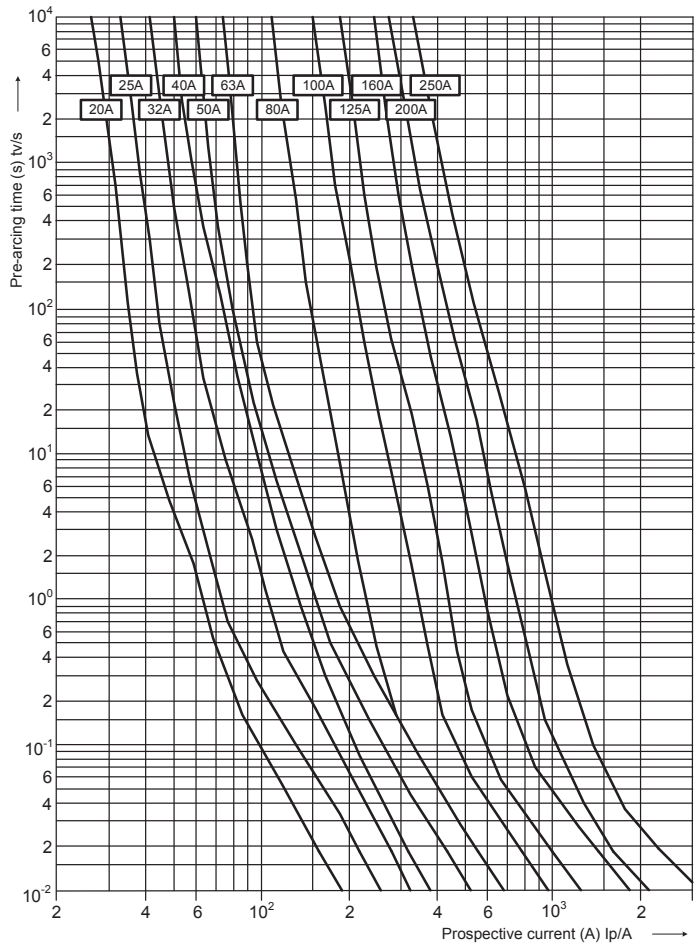

Time-current characteristics NH1C and NH1

Dimensions NH Battery fuses 80 V d.c.

pic. 1

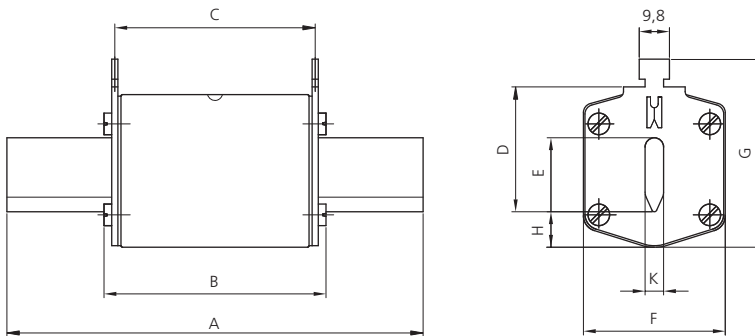

Size	A	B	C	D	E	F	G	H	K
00 C	79	53	47	35	15	21	52	7,5	6
00	79	53	47	35	15	28	56	12	6
1 C	135	68	65	40	15	28	61	12	6
1	135	72	65	40	20	46	65	14	6

Fuses for protection of forklift batteries TRB

General characteristics	
Rated voltage	80V d.c.
Standards	DIN 43560/1
Application	TRB fuse-links are used to protect the forklift battery

TRB				
I _n [A]	Type	Code Nr.	Weight [g]	Packaging [pcs]
35	TRB 35A/80V	004341020	10	20
50	TRB 50A/80V	004341021		
63	TRB 63A/80V	004341022		
80	TRB 80A/80V	004341023		
100	TRB 100A/80V	004341024		
125	TRB 125A/80V	004341025		
160	TRB 160A/80V	004341026		
200	TRB 200A/80V	004341027		
250	TRB 250A/80V	004341028		
300	TRB 300A/80V	004341029		
355	TRB 355A/80V	004341030		
425	TRB 425A/80V	004341031		



Dimensions TRB fuses

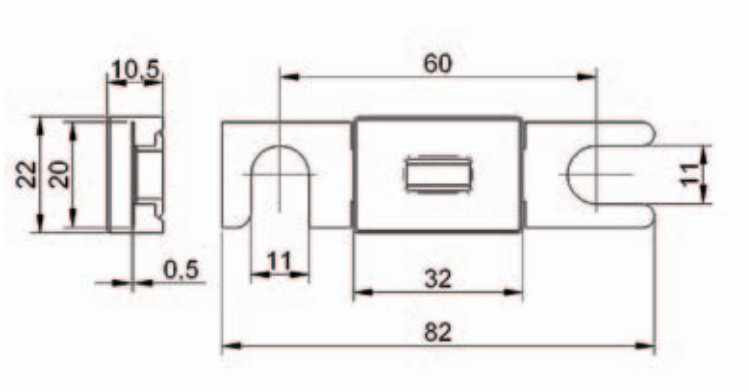

NH BATTERY fuse link 550V d.c.

General characteristics	
Rated voltage	550V d.c. (L/R=10ms)
Breaking capacity	30kA d.c.
Standard	IEC 60269
Application	Battery protection

NH BATTERY fuse link							
Size	I_n	Standard indicator	Striker indicator	Standard indicator S110mm	Power dissipation	Weight	Pack.
	[A]	pic. 1	pic. 1	pic. 2	[W]	[g]	[pcs]
1	40	004723259	004723279	004723269	6	420	3/24
	50	004723260	004723280	004723270	7		
	63	004723261	004723281	004723271	9		
	80	004723262	004723282	004723272	12		
	100	004723263	004723283	004723273	15		
	125	004723264	004723284	004723274	20		
	160	004723265	004723285	004723275	26		
	200	004723266	004723286	004723276	32		
	224	004723267	004723287	004723277	37		
2	250	004723268	004723288	004723278	43	660	3/24
	125	004724260	004724280	004724270	20		
	160	004724261	004724281	004724271	26		
	200	004724262	004724282	004724272	32		
	224	004724263	004724283	004724273	37		
	250	004724264	004724284	004724274	43		
	315	004724265	004724285	004724275	57		
	350	004724266	004724286	004724276	67		
	400	004724267	004724287	004724277	76		
3	250	004725260	004725280	004725270	43	870	3/24
	315	004725261	004725281	004725271	57		
	350	004725262	004725282	004725272	67		
	400	004725263	004725283	004725273	76		
	425	004725264	004725284	004725274	84		
	500	004725265	004725285	004725275	110		
630	004725266	004725286	004725276	160			



NH BATTERY fuse link 700V d.c.

General characteristics	
Rated voltage	700V d.c. (L/R=10ms)
Breaking capacity	30kA d.c.
Standard	IEC 60269
Application	Battery protection

NH BATTERY fuse link 700 V d.c.							
Size	I_n	Standard indicator pic. 1	Striker indicator pic. 1	Standard indicator S110mm pic. 2	Power dissipation [W]	Weight [g]	Pack. [pcs]
1	40	004723289	004723309	004723299	6	420	3/24
	50	004723290	004723310	004723300	7		
	63	004723291	004723311	004723301	9		
	80	004723292	004723312	004723302	12		
	100	004723293	004723313	004723303	15		
	125	004723294	004723314	004723304	20		
	160	004723295	004723315	004723305	26		
	200	004723296	004723316	004723306	32		
	224	004723297	004723317	004723307	37		
	250	004723298	004723318	004723308	43		
2	125	004724290	004724310	004724300	20	660	3/24
	160	004724291	004724311	004724301	26		
	200	004724292	004724312	004724302	32		
	224	004724293	004724313	004724303	37		
	250	004724294	004724314	004724304	43		
	315	004724295	004724315	004724305	57		
	350	004724296	004724316	004724306	67		
3	250	004725290	004725304	004725297	43	870	3/24
	315	004725291	004725305	004725298	57		
	350	004725292	004725306	004725299	67		
	400	004725293	004725307	004725300	76		
	425	004725294	004725308	004725301	84		
	500	004725295	004725309	004725302	110		
630	004725296	004725310	004725303	160			



NH BATTERY fuse link 800V d.c.

General characteristics	
Rated voltage	800V d.c. (L/R=10ms)
Breaking capacity	30kA d.c.
Standard	IEC 60269
Application	Battery protection

NH BATTERY fuse link 700 V d.c.							
Size	I _n	Standard indicator	Striker indicator	Standard indicator S110mm	Power dissipation [W]	Weight [g]	Pack. [pcs]
		pic. 1	pic. 1	pic. 2			
1	40	004723320	004723330	004723340	6	420	3/24
	50	004723321	004723331	004723341	7		
	63	004723322	004723332	004723342	9		
	80	004723323	004723333	004723343	12		
	100	004723324	004723334	004723344	15		
	125	004723325	004723335	004723345	20		
	160	004723326	004723336	004723346	26		
2	200	004723327	004723337	004723347	32	660	3/24
	125	004724320	004724330	004724340	20		
	160	004724321	004724331	004724341	26		
	200	004724322	004724332	004724342	32		
	224	004724323	004724333	004724343	37		
	250	004724324	004724334	004724344	43		
	315	004724325	004724335	004724345	57		
350	004724326	004724336	004724346	67			
400	004724327	004724337	004724347	76			



Dimensions NH Battery fuses

pic. 1

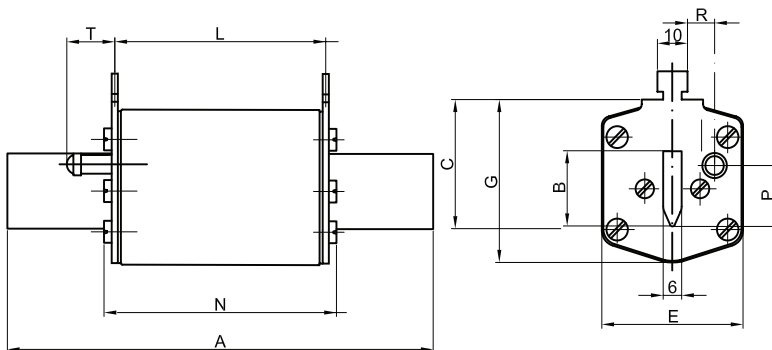

Size	A	B	C	E	G	S	L	N	P	R	T
1	135	24	40	46	52	6	65	73	20,5	13,7	27,5
2	150	30	48	54	61	6	65	73	27,3	16,2	27,5
3	150	37	60	64	74	6	65	73	35,6	17	27,5

pic. 2

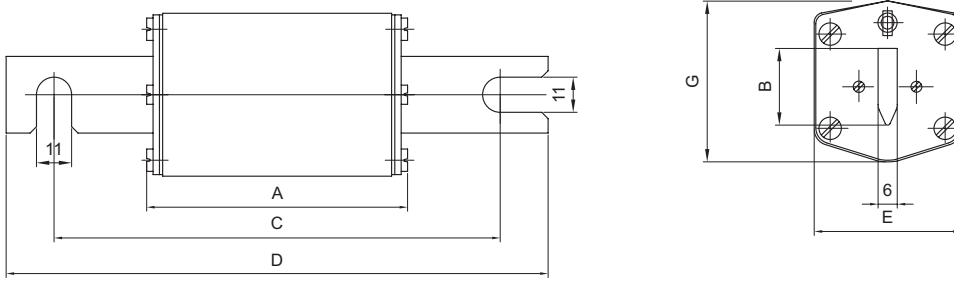

Size	A	B	C	D	E	G
1	72	24	110	140	46	51
2	72	30	110	140	54	59
3	72	37	110	140	64	70

I/t characteristics for NH Battery fuses

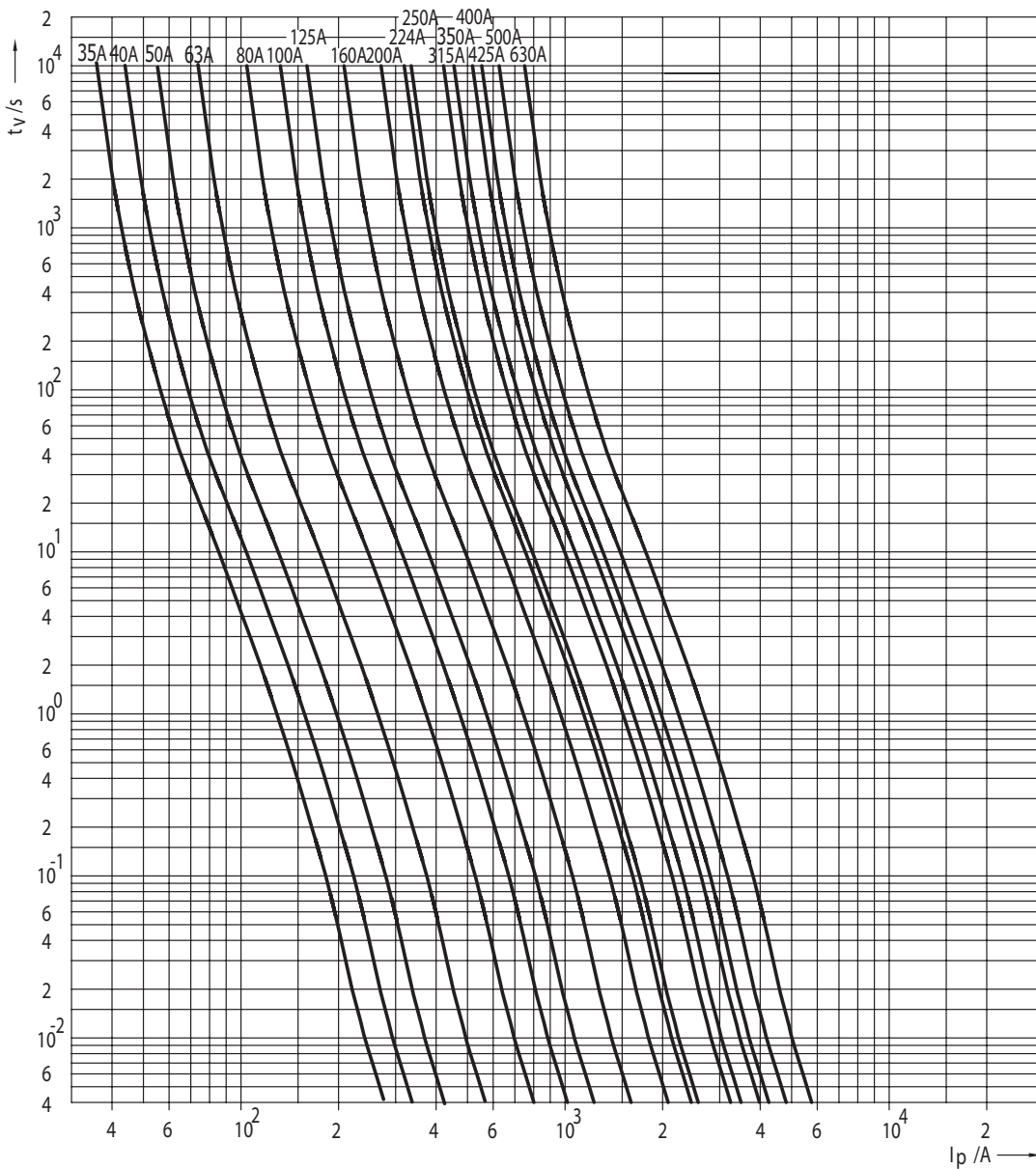

Fuel Cell Fuses

The characteristics of fuel cell fuses FCF are developed according to standard ISO 8820-7 to meet the needs of fuel cell protection. Fuse links are used in fuel cell applications up to the nominal voltage 450V d.c. and maximum breaking capacity 2000A at time constant up to 10ms. Minimum breaking capacity is $2 \times I_n$ at nominal voltage.

Without the protection of the specially designed FCF, the high DC voltage could experience severe arcing, thermal incidents or other hazards in the event of the overload or short circuit on fuel cells.

The design of FCF is based on DC fuses. It has been redesigned to fit the needs the fuel cell protection acc. to Standard ISO 8820-7 2007.

Fuel cell fuse-FCF is a reverse current protection device for a fuel cell of a power circuit and it protects the fuel cell from damage caused by reverse current into the fuel cell.

General characteristics	
Rated voltage:	450V d.c. (L/R=10ms)
Breaking capacity:	2kA d.c.
Standard:	ISO 8820-7
Application:	For protection of fuel cells



CH 10x38 FUEL CELL FUSE DC								
Size	I_n [A]	Code No. type SU contacts 450V d.c.	Pre-arcing Joule integral [A ² s] L/R=10ms	Operating Joule integral [A ² s] L/R=10ms	Power dissipation [0,7 x I_n] P_d [W]	Power dissipation [$1 \times I_n$] P_d [W]	Weight [g]	Packaging [pcs]
10x38	4	002626202	12	24	0,3	0,6	12	10/380
	6	002626204	26	52	0,4	0,9		
	8	002626206	9	21	0,6	1,3		
	10	002626208	22	55	0,6	1,35		
	12	002626210	61	111	0,6	1,35		
	16	002626212	105	237	0,8	1,8		
	20	002626214	215	371	1,0	2,2		

